

# Panasonic®

## Operating Instructions Digital Camera

Model No. **DMC-FX9PP**

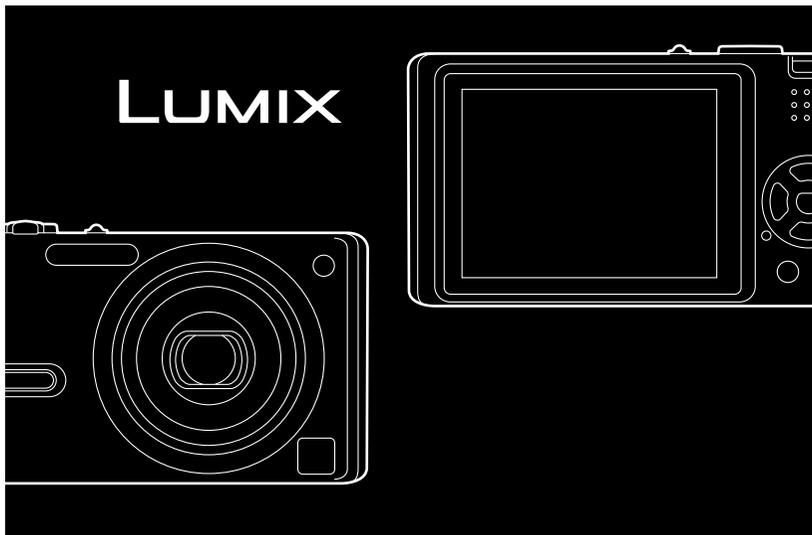
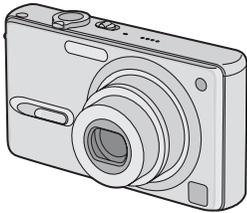

**LEICA**  
**DC VARIO-ELMARIT**

Before connecting, operating or  
adjusting this product, please read  
the instructions completely.

For USA assistance, please call: 1-800-272-7033 or send e-mail to : [digitalstillcam@panasonic.com](mailto:digitalstillcam@panasonic.com)

For Canadian assistance, please call: 1-800-561-5505 or visit us at [www.panasonic.ca](http://www.panasonic.ca)

VQT0S57

*Before Use*

**Dear Customer,**

We would like to take this opportunity to thank you for purchasing this Panasonic Digital Camera. Please read these Operating Instructions carefully and keep them handy for future reference.

## Information for Your Safety

---

**WARNING**

**TO REDUCE THE RISK OF FIRE OR SHOCK HAZARD AND ANNOYING INTERFERENCE, USE ONLY THE RECOMMENDED ACCESSORIES AND DO NOT EXPOSE THIS EQUIPMENT TO RAIN OR MOISTURE. DO NOT REMOVE THE COVER (OR BACK); THERE ARE NO USER SERVICEABLE PARTS INSIDE. REFER SERVICING TO QUALIFIED SERVICE PERSONNEL.**

**Carefully observe copyright laws.**

**Recording of pre-recorded tapes or discs or other published or broadcast material for purposes other than your own private use may infringe copyright laws. Even for the purpose of private use, recording of certain material may be restricted.**

- Please note that the actual controls and components, menu items, etc. of your Digital Camera may look somewhat different from those shown in the illustrations in these Operating Instructions.
- SD Logo is a trademark.
- Other names, company names, and product names printed in these instructions are trademarks or registered trademarks of the companies concerned.

THE SOCKET OUTLET SHALL BE INSTALLED NEAR THE EQUIPMENT AND SHALL BE EASILY ACCESSIBLE.

**CAUTION**

Danger of explosion if battery is incorrectly replaced. Replace only with the same or equivalent type recommended by the manufacturer. Dispose of used batteries according to the manufacturer's instructions.



A lithium ion/polymer battery that is recyclable powers the product you have purchased. Please call 1-800-8-BATTERY for information on how to recycle this battery.

Before Use

**FCC Note: (U.S. only)**

This equipment has been tested and found to comply with the limits for a Class B digital device, pursuant to Part 15 of the FCC Rules. These limits are designed to provide reasonable protection against harmful interference in a residential installation. This equipment generates, uses, and can radiate radio frequency energy and, if not installed and used in accordance with the instructions, may cause harmful interference to radio communications. However, there is no guarantee that interference will not occur in a particular installation. If this equipment does cause harmful interference to radio or television reception, which can be determined by turning the equipment off and on, the user is encouraged to try to correct the interference by one or more of the following measures:

- Reorient or relocate the receiving antenna.
- Increase the separation between the equipment and receiver.
- Connect the equipment into an outlet on a circuit different from that to which the receiver is connected.
- Consult the dealer or an experienced radio/TV technician for help.

FCC Caution: To assure continued compliance, follow the attached installation instructions and use only shielded interface cables with ferrite core when connecting to computer or peripheral devices.

Any changes or modifications not expressly approved by the party responsible for compliance could void the user's authority to operate this equipment.

Trade Name: Panasonic  
Model No.: DMC-FX9  
Responsible party: Panasonic Corporation of North America  
One Panasonic Way, Secaucus, NJ 07094  
Support Contact: Panasonic Consumer Electronics Company  
1-800-272-7033

This device complies with Part 15 of the FCC Rules. Operation is subject to the following two conditions: (1) This device may not cause harmful interference, and (2) this device must accept any interference received, including interference that may cause undesired operation.

This Class B digital apparatus complies with Canadian ICES-003



**-If you see this symbol-**

**Information on Disposal in other Countries outside the European Union**

This symbol is only valid in the European Union.

If you wish to discard this product, please contact your local authorities or dealer and ask for the correct method of disposal.



■ **Care for the camera**

- **Do not shake or cause impact to the camera.** The camera may not be operated normally or recording of pictures may be disabled, or the lens may be damaged.
- **Sand or dust may cause a malfunction of the camera. When you use the camera on a beach etc., take care so that sand or dust does not get into the camera.**
- When you use the camera on a rainy day or on a beach, take care so that water does not get into the camera.
- **If seawater splashes onto the camera, wet a soft cloth with tap water, wring it well, and use it to wipe the camera body carefully. Then, wipe it again with a dry cloth.**

■ **About the LCD monitor**

- **Do not press the LCD monitor strongly. It may cause uneven colors on the LCD monitor or a malfunction of the LCD monitor.**
- In a place with drastic temperature changes, condensation may form on the LCD monitor. Wipe it with a soft, dry cloth.
- If the camera is extremely cold when you turn the camera on, the picture on the LCD monitor is slightly darker than usual at first. However, as the internal temperature increases, it goes back to the normal brightness.

Extremely high precision technology is employed to produce the LCD monitor screen. The result is more than 99.99% effective pixels with a mere 0.01% of the pixels inactive or always lit. However, this will not be recorded on the pictures in the card.

■ **About the Lens**

- Do not direct the lens to the sun or strong light sources. It may cause not only a malfunction of the camera but irreversible damage to your eye.
- Do not press the lens strongly.
- Leaving the camera with the lens facing the sun may cause a malfunction. Be careful when you put the camera outside or near a window.

■ **About Condensation (When the lens is fogged up)**

Condensation takes place when the ambient temperature or humidity is changed as follows:

Be careful of condensation since it causes stains on the lens, fungus or malfunction.

- When the camera is brought inside from the cold to a warm room.
- When the camera is moved from outside to an air-conditioned car.
- When cool wind from an air conditioner or other is directly blown onto the camera.
- In humid places

Put the camera into plastic bag until the temperature of the camera is close to the ambient temperature to avoid condensation. In case of condensation, turn the camera off and then leave it for about 2 hours.

When the camera becomes close to the ambient temperature, the fog disappears naturally.

■ **If you will not be using the camera for a long time**

- Store the battery in a cool and dry place with a relatively stable temperature.  
[Recommended temperature: 15 °C to 25 °C (59 °F to 77 °F),  
Recommended humidity: 40% to 60%]
- Be sure to remove the battery and the card from the camera.
- When the battery is left inserted in the camera for a long time, discharge takes place even if the camera is turned off. If you leave the battery inserted for an extended period of time, it will be excessively discharged and it may become unusable even after it is charged.
- To store the battery for a long period of time, we recommend charging it once every year and storing it again after you completely use up the charged capacity.
- When you keep the camera in a closet or a cabinet, we recommend storing it with the desiccant (silica gel).

## About These Operating Instructions

---

Please note that the description on this page is a sample and all pages are not described in this manner.

### Compensating the Exposure

---



Use this function when you cannot achieve appropriate exposure due to the difference of brightness between the subject and the background.



- EV is an abbreviation of Exposure Value, and it is the amount of light given to the CCD by the aperture value and the shutter speed.



Modes indicated here allow you to use the functions or settings described on this page. Set the Mode dial to any of the modes to use the functions or settings.

2 Convenient or helpful information for use of the camera is described.

#### ■ About illustrations in these operating instructions

Please note that the appearance of the product, the illustration or the menu screen are a little different from those in actual use.

#### ■ About illustrations of the cursor button

In these operating instructions, the operations on the cursor button are described as illustrated below.

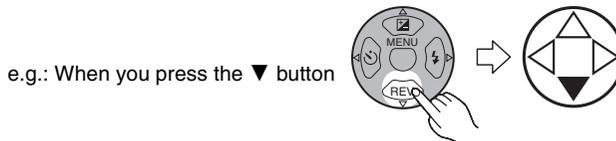

## Contents

<hr/> <hr/> <b>Before Use</b> <hr/> <hr/>		Using the Playback Zoom ..... 50
Information for Your Safety ..... 2		Deleting Pictures ..... 51
About These Operating Instructions ..... 6		
<hr/> <hr/> <b>Preparation</b> <hr/> <hr/>		
Standard Accessories ..... 9		
Names of the Components ..... 10		
Quick Guide ..... 12		
Charging the Battery with the Charger ... 13		
About the Battery (charging/ number of recordable pictures) ..... 14		
Inserting/Removing the Battery ..... 15		
Inserting/Removing the Card ..... 16		
About the Card ..... 17		
Approximate number of recordable pictures and the size .... 18		
Setting Date/Time (Clock Set) ..... 20		
About the Setup Menu ..... 21		
About the LCD Monitor ..... 25		
<hr/> <hr/> <b>Recording pictures (basic)</b> <hr/> <hr/>		
Taking Pictures ..... 28		
Taking Pictures in Simple Mode ..... 33		
Checking the Recorded Picture (Review) ..... 36		
Using the Optical Zoom ..... 37		
Taking Pictures using the Built-in Flash ..... 38		
Taking Pictures with the Self-timer ..... 41		
Compensating the Exposure ..... 42		
Taking Pictures using Auto Bracket ..... 43		
Optical Image Stabilizer ..... 44		
Taking Pictures using Burst Mode ..... 45		
<hr/> <hr/> <b>Playback (basic)</b> <hr/> <hr/>		
Playing Back Pictures ..... 47		
Multi Playback (9 screens, 16 screens, and 25 screens) ..... 48		
<hr/> <hr/> <b>Recording pictures (advanced)</b> <hr/> <hr/>		
Using the Mode Dial ..... 53		
• Macro mode ..... 53		
• Motion picture mode ..... 53		
• Scene mode ..... 56		
– Portrait mode ..... 57		
– Sports mode ..... 57		
– Food mode ..... 58		
– Scenery mode ..... 58		
– Night portrait mode ..... 59		
– Night scenery mode ..... 59		
– Baby mode ..... 60		
– Soft skin mode ..... 61		
– Candle light mode ..... 61		
– Party mode ..... 62		
– Fireworks mode ..... 62		
– Snow mode ..... 63		
– Starry sky mode ..... 63		
– Self portrait mode ..... 64		
<hr/> <hr/> <b>Recording Menu Settings</b> <hr/> <hr/>		
Using the [REC] mode menu ..... 66		
• White Balance [W.BALANCE] ..... 67		
• ISO Sensitivity [SENSITIVITY] ..... 69		
• Aspect Ratio [ASPECT RATIO] ..... 69		
• Picture Size [PICT.SIZE] ..... 70		
• Quality [QUALITY] ..... 72		
• Audio Recording [AUDIO REC.] ..... 72		
• AF Mode [AF MODE] ..... 73		
• AF Assist Lamp [AF ASSIST LAMP] ..... 74		
• Slow Shutter [SLOW SHUTTER] ..... 75		
• Digital Zoom [D.ZOOM] ..... 75		
• Color Effect [COL.EFFECT] ..... 76		
• Picture Adjustment [PICT.ADJ.] ..... 76		

---

---

## Playback (advanced)

---

---

Playing Back Pictures with Audio/ Motion Pictures .....	77
Using the [PLAY] mode menu .....	78
• Playing Back with Slide Show [SLIDE SHOW] .....	79
• Setting Favorites [FAVORITE] .....	80
• Displaying pictures in a direction at the time of recording [ROTATE DISP.] .....	81
• Rotating the Picture [ROTATE] .....	82
• Setting the Picture to be Printed and the Number of Prints [DPOF PRINT] .....	83
• Preventing Accidental Erasure of the Picture [PROTECT] .....	85
• Adding Audio to Recorded Pictures [AUDIO DUB.] .....	86
• Resizing the Pictures [RESIZE] .....	87
• Trimming the Pictures [TRIMMING] .....	88
• Clean-up [CLEAN UP] .....	90
• Initializing the Card [FORMAT] .....	91
Playing Back Pictures on a TV Screen...	92

---

---

## Connecting to a PC or Printer

---

---

Before Connecting to the PC or the Printer [USB MODE] .....	93
Connecting to a PC .....	94
Connecting to a PictBridge-compliant Printer .....	96

---

---

## Others

---

---

Screen Display .....	100
Cautions for Use .....	103
Message Display .....	105
Troubleshooting .....	107
Specifications .....	111
Digital Camera Accessory System .....	113
Digital Camera Accessory Order Form (For USA Customers) .....	114
Request for Service Notice (For USA Only) .....	115
Limited Warranty (For USA Only) .....	116
Customer Services Directory (For USA Only) .....	118
Index .....	119
Spanish Quick Use Guide/ Guía rápida en español .....	121

## Standard Accessories

Before using your camera, check the contents.

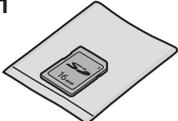
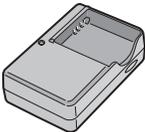
<p><b>1</b></p>  <p>RP-SD016B</p>	<p><b>2</b></p>  <p>CGA-S005A</p>
<p><b>3</b></p>  <p>DE-A11B</p>	<p><b>4</b></p>  <p>K1HA08CD0004</p>
<p><b>5</b></p>  <p>K1HA08CD0005</p>	<p><b>6</b></p> 
<p><b>7</b></p>  <p>VFC4090</p>	<p><b>8</b></p>  <p>VYQ3509</p>

- 1 SD Memory Card (16 MB)  
(In the text, it is indicated as “Card”)
- 2 Battery Pack  
(In the text, it is indicated as “Battery”)
- 3 Battery Charger  
(In the text, it is indicated as “Charger”)
- 4 USB Connection Cable
- 5 AV Cable
- 6 CD-ROM
- 7 Strap
- 8 Battery Carrying Case

- For information about optional accessories, please refer to “Digital Camera Accessory System”. (P113)
- If any of the accessories are lost, please contact Panasonic’s parts department at 1 800 833-9626 (For USA) or in Canada call 1 800 561-5505 for more details on how to obtain replacement parts.

## Names of the Components

---

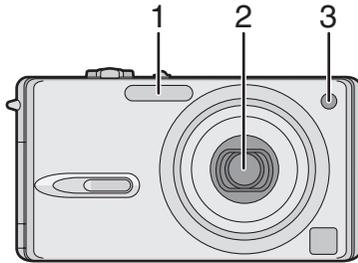

- 1 Photo Flash (P38)
- 2 Lens (P5)
- 3 Self-timer Indicator (P41)  
AF Assist Lamp (P74)

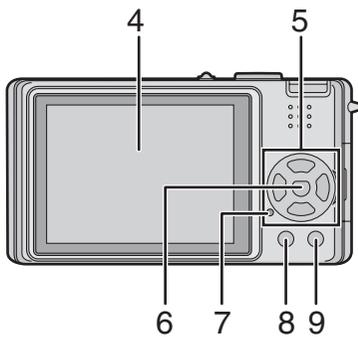

- 4 LCD Monitor (P25, 100)
- 5 Cursor Buttons
  - ◀/Self-timer Button (P41)
  - ▼/[REV] Button (P36)
  - ▶/Flash Setting Button (P38)
  - ▲/Exposure Compensation (P42)/Auto Bracket (P43)/White Balance Fine Adjustment (P68)/Backlight Compensation in Simple Mode (P35) Button
- 6 [MENU] Button (P21)
- 7 Status Indicator (P14, 23)
- 8 [DISPLAY/PWR LCD] Button (P25, 26)
- 9 Single or Burst Mode (P45)/Delete (P51) Button

Preparation

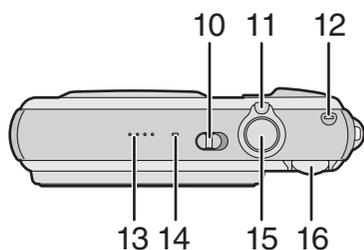

- 10 Camera ON/OFF Switch (P12)
- 11 Zoom Lever (P37, 71, 75)
- 12 Optical Image Stabilizer Button (P44)
- 13 Speaker (P77)
- 14 Microphone (P54, 72)
- 15 Shutter Button (P29, 54)
- 16 Mode Dial (P28)

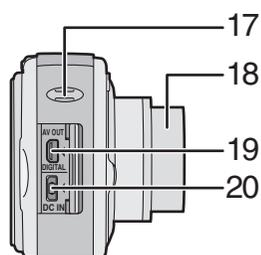

17 Strap Eyelet

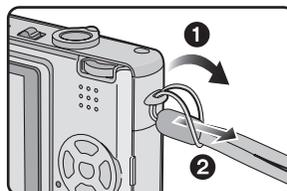

- 18 Lens Barrel
- 19 [AV OUT/DIGITAL] Socket (P92, 94, 96)
- 20 [DC IN] Socket (P94, 96)
  - Please be sure to use genuine Panasonic AC adaptor (DMW-AC5; optional).
  - This camera cannot charge the battery even though the AC adaptor (DMW-AC5; optional) is connected to it.

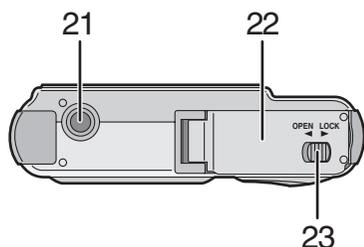

- 21 Tripod Receptacle
  - When you use a tripod, make sure the tripod is stable when the camera is attached to it.
- 22 Card/Battery Door (P15, 16)
- 23 Release lever (P15, 16)

## Quick Guide

This is the overview of the procedure to record and playback pictures with the camera. For each operation, be sure to refer to the corresponding pages.

### 1 Charge the battery. (P13)

- When the camera is shipped, the battery is not charged. Charge the battery before use.

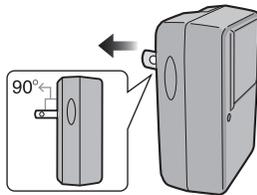

### 2 Insert the battery and the card. (P15, 16)

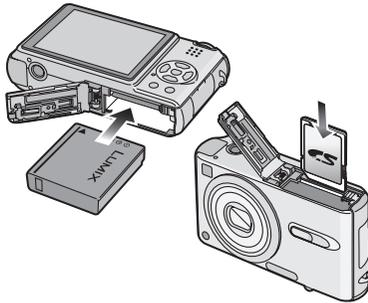

### 3 Turn the camera on to take pictures.

- Set the clock. (P20)

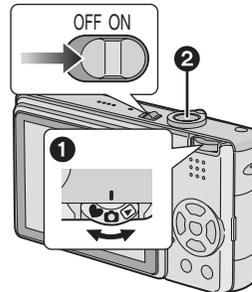

- 1 Set the mode dial to [📷].
- 2 Press the shutter button to take pictures. (P29)

### 4 Play back the pictures.

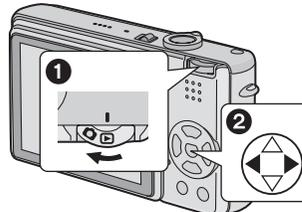

- 1 Set the mode dial to [▶].
- 2 Select the picture you want to view. (P47)

## Charging the Battery with the Charger

When the camera is shipped, the battery is not charged. Charge the battery before use.

### 1 Attach the battery with attention to the direction of the battery.

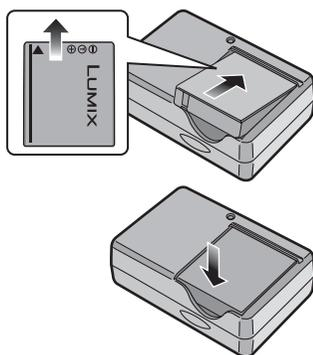

### 2 Connect the charger to the electrical outlet.

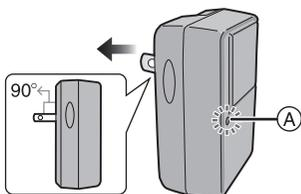

- When the [CHARGE] indicator (A) lights in green, charging starts.
- When the [CHARGE] indicator (A) turns off (in about 130 minutes), charging is completed.

### 3 Detach the battery after charging is completed.

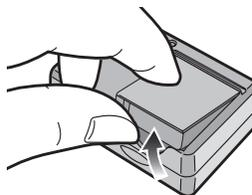

- After charging is completed, be sure to disconnect the charger from the electrical outlet.
- The battery becomes warm after use/charge or during charge. The camera also becomes warm during use. However, it is not a malfunction.
- The battery is exhausted when it is left for a long period of time after being charged. Recharge the battery when it is exhausted.
- **Use the dedicated charger and battery.**
- **Charge the battery with the charger indoors.**
- **Do not disassemble or modify the charger.**

## About the Battery (charging/number of recordable pictures)

### ■ Battery indication

The remaining battery power appears on the screen. [It does not appear when you use the camera along with the AC adaptor (DMW-AC5; optional).]



- The battery indication turns red and blinks. (When the LCD monitor is set to off by the economy mode, the status indicator blinks.)
- Recharge the battery or replace it with fully charged battery.

### ■ The battery life

#### The number of recordable pictures by CIPA standard (In normal picture mode)

- CIPA is an abbreviation of [Camera & Imaging Products Association].

<b>Number of recordable pictures</b>	Approx. 270 pictures (Approx. 135 min)
--------------------------------------	---

#### Recording conditions by CIPA standard

- Temperature: 23 °C (73.4 °F)/ Humidity: 50% when LCD monitor is on.\*
- Using the supplied SD Memory Card (16 MB).
- Using the supplied battery.
- Recording starts 30 seconds after the camera is turned on.
- **Recording once every 30 seconds**, with full flash every other recording.
- Rotating the zoom lever towards Tele to Wide and vice versa in every recording.
- Turn the camera off every 10 recordings./ Leaving the camera until the battery is cooled down.

\*When the Power LCD function (P26) is used, the number of recordable pictures decreases.

**The number of recordable pictures varies depending on the recording interval time. If the recording interval time becomes longer, the number of recordable pictures decreases.**  
[e.g., when taking pictures every 2 minutes: about 1/4 of the amount (Approx. 67 pictures) when recording once every 30 seconds]

### Playback time

<b>Playback time</b>	Approx. 310 min
----------------------	-----------------

The number of recordable pictures and playback time will vary depending on the operating conditions and storing condition of the battery.

### ■ Charging

<b>Charging time</b>	Approx. 130 min
----------------------	-----------------

Charging time and the number of recordable pictures with the optional battery pack (CGA-S005A) are the same as above.

- When charging starts, the [CHARGE] indicator lights.

### ■ Charging error

- If a charging error occurs, the [CHARGE] indicator blinks in about 1 second cycles. In this case, disconnect the charger from the electrical outlet, remove the battery and make sure that both room and battery temperature are not too low or high and then charge it again. If the [CHARGE] indicator still blinks even if you charge the battery for a while, consult the dealer or your nearest servicenter.
- When the operating time of the camera becomes extremely short even if the battery is properly charged, the life of the battery may have expired. Buy a new battery.

### ■ Charging conditions

- Charge the battery under temperature of 10 °C to 35 °C (50 °F to 95 °F). (Battery temperature should be the same also.)
- The performance of the battery may be temporarily deteriorated and the operating time may become shorter in low temperature conditions (e.g. skiing/ snowboarding).

## Inserting/Removing the Battery

- Check that the camera is turned off and that the lens is retracted.

**1** Slide the release lever to the direction of arrow, and open the card/battery door.

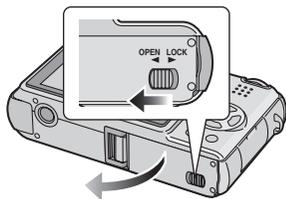

- Please be sure to use genuine Panasonic batteries (CGA-S005A).

**2** Insert:  
Insert the charged battery fully paying attention to the direction of the battery.

Remove:  
Slide the lock (A) to remove the battery.

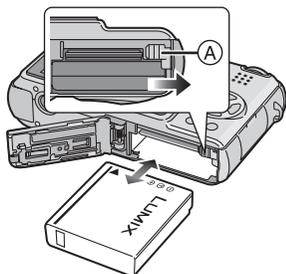

**3** **1** Close the card/battery door.  
**2** Slide the release lever to the direction of arrow.

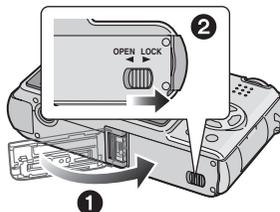

- If you will not be using the camera for a long time, remove the battery. Store the removed battery in the battery carrying case (supplied). (P104)
- When a fully charged battery has been inserted for more than 24 hours, the clock setting is stored (in the camera) for at least 3 months even if the battery is removed. (The storing time may be shorter if the battery is not charged sufficiently.)  
If more than 3 months has passed, the clock setting will be lost. In this case, set the clock again. (P20)
- Do not remove the card and the battery while the card is being accessed. The data on the card may be damaged. (P17)
- Do not remove the battery with the camera turned on since the settings on the camera may not be stored properly.
- The supplied battery is designed only for the camera. Do not use it with any other equipment.

## Inserting/Removing the Card

- Check that the camera is turned off and that the lens is retracted.

**1** Slide the release lever to the direction of arrow, and open the card/battery door.

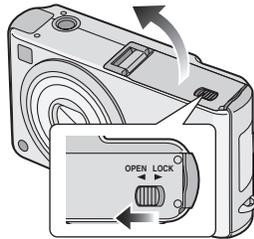

- The card and the data may be damaged if it is inserted or removed while the camera is turned on.
- We recommend using Panasonic's SD Memory Card. (Use only genuine SD cards with an SD Logo.)

**2** Insert:

Insert the card fully with the label side facing the front of the camera until it clicks.

**Remove:**

Push the card until it clicks, then pull the card out upright.

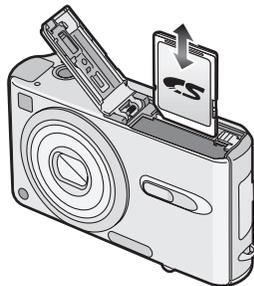

- Check the direction of the card.
- Do not touch the connection terminals on the back side of the card.
- The card may be damaged if it is not fully inserted.

**3** ① Close the card/battery door.

② Slide the release lever to the direction of arrow.

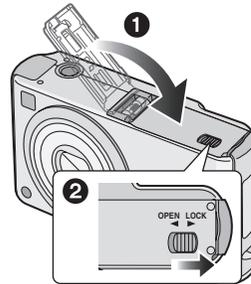

- If the card/battery door cannot be completely closed, remove the card and insert it again.

## About the Card

### ■ Access to the card

When pictures are being recorded onto the card, the card access indication **(A)** lights red.

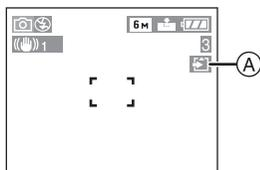

When the card access indication lights, pictures are being read or deleted, or the card is cleaned up (P90) or formatted, do not:

- turn the camera off.
- remove the battery or the card.
- shake or impact the camera.

The card and the data may be damaged and the camera may not operate normally.

### ■ About handling a card

Transfer important pictures/motion pictures from your card to your PC periodically (P94). The data on the card may be damaged or lost due to electromagnetic wave, static electricity, breakdown of the camera or a defective card.

- Do not format the card on your PC or other equipment, format it with the camera only to ensure proper operation. (P91)

### ■ SD Memory Card (supplied) and MultiMediaCard (optional)

The SD Memory Card and MultiMediaCard are small, lightweight, removable external cards. The reading/writing speed of an SD Memory Card is fast. The SD Memory Card is equipped with a Write-Protect switch **(B)** that can inhibit writing and formatting a card. (When the switch is slid to the [LOCK] side, it is not possible to write or delete data on the card and format it. When the switch is unlocked, these functions become available.)

### SD Memory Card

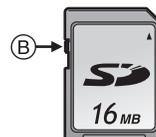

On this unit, you can use SD Memory Cards of the following capacity (from 8 MB to 2 GB).

**8 MB, 16 MB, 32 MB, 64 MB, 128 MB, 256 MB, 512 MB, 1 GB, 2 GB (Maximum)**

Please confirm the latest information on the following website.

<http://panasonic.co.jp/pavc/global/cs>

(This Site is English only.)

- This unit supports SD Memory Cards formatted in FAT12 system and FAT16 system based on SD Memory Card Specifications.
- This unit does not support MultiMediaCard for recording motion pictures.



- The reading/writing speed of a MultiMediaCard is slower than an SD Memory Card. When a MultiMediaCard is used, the performance of certain features may be slightly slower than advertised.
- Keep the Memory Card out of reach of children to prevent swallowing.

## Approximate number of recordable pictures and the size

Aspect ratio	4:3							
Picture size	6M (6M): (2816×2112 pixels)		3M (3M EZ): (2048×1536 pixels)		2M (2M EZ): (1600×1200 pixels)		1M (1M EZ): (1280×960 pixels)	
Quality								
16 MB	4	9	9	17	14	28	22	41
32 MB	10	20	19	37	30	59	46	86
64 MB	20	41	39	75	62	120	94	175
128 MB	42	83	79	150	125	240	190	350
256 MB	82	160	150	290	240	470	370	690
512 MB	160	320	300	590	480	940	730	1370
1 GB	320	640	610	1180	970	1880	1470	2740
2 GB	660	1280	1220	2360	1920	3610	2920	5120

Aspect ratio	4:3		3:2			
Picture size	0.3M (0.3M EZ): (640×480 pixels)		5M (5M): (2816×1880 pixels)		2.5M (2.5M EZ): (2048×1360 pixels)	
Quality						
16 MB	69	110	5	10	10	19
32 MB	145	230	11	22	21	41
64 MB	290	480	23	46	44	84
128 MB	600	970	47	93	89	170
256 MB	1170	1900	92	180	170	330
512 MB	2320	3770	180	350	340	650
1 GB	4650	7550	360	710	680	1310
2 GB	8780	12290	740	1420	1360	2560

Preparation

Aspect ratio	16:9			
Picture size	4.5M (4.5M): (2816×1584 pixels)		2M (2M EZ): (1920×1080 pixels)	
Quality				
16 MB	6	12	13	25
32 MB	13	26	28	54
64 MB	27	54	58	110
128 MB	56	110	115	220
256 MB	105	210	230	430
512 MB	210	420	450	860
1 GB	430	850	910	1720
2 GB	870	1700	1800	3410



- The aspect ratio is the horizontal to vertical ratio of a picture. Refer to P69 for the aspect ratio.
- If you select a larger picture size, you can print pictures more clearly. When you select a smaller picture size, you can record more pictures. (P70)
- “EZ” is an abbreviation for [Extended Optical Zoom]. This is a function which further extends the optical zoom ratio. If you select a picture size with EZ displayed, the zoom ratio is extended to a maximum of 4.1× when the digital zoom is set to [OFF]. (P71)
- Refer to P72 for information about quality.
- The numbers are approximations. (The numbers vary depending on the recording condition and the type of the card.)
- The number of recordable pictures varies depending on subjects.
- The remaining number of recordable pictures displayed on the screen is an approximation.

## Setting Date/Time (Clock Set)

### ■ Initial setting

The clock is not set when the camera is shipped. When you turn the camera on, the following screen appears.



- When pressing the [MENU] button, the screen shown in step 1 appears.
- The screen disappears after about 5 seconds. Turn the camera on again or press the [MENU] button, select [CLOCK SET] in page 2/3 of the [SETUP] menu (P21) and set the clock in steps 1 and 2.

### 1 Set date and time.

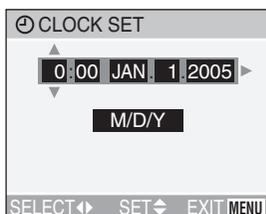

- ◀/▶: Select the desired item.
- ▲/▼: Set date and time.

### 2 Select [M/D/Y], [D/M/Y] or [Y/M/D].

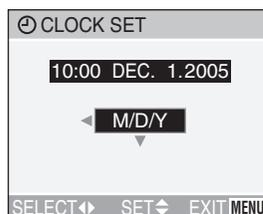

- Close the menu by pressing the [MENU] button 2 times after finishing the setting.
- Check if the clock setting is correct, after turning the camera off and on.



- When a fully charged battery has been inserted for more than 24 hours, the clock setting is stored (in the camera) for at least 3 months even if the battery is removed. (The storing time may be shorter if the battery is not charged sufficiently.)  
If more than 3 months has passed, the clock setting will be lost. In this case, set the clock again.
- You can set the year from 2000 to 2099. The 24-hour system is used.
- When you use a photo printing service, if the date is not set in the camera, it will not be printed, even if the store provides a date printing option to your photo.
- For the date print setting, refer to P84.

## About the Setup Menu

- Set the items if necessary. (Refer to P22–24 for each menu item.)

### 1 Turn the camera on.

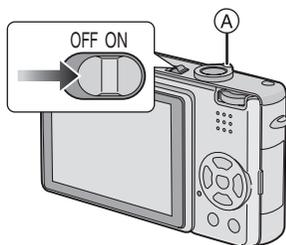

- The menu items depend on the mode selected with the mode dial (P28). In this page, the items in normal picture mode [📷] are indicated.

### 2 Press the [MENU] button.

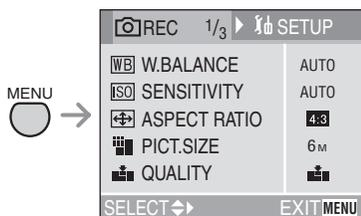

### 3 Select the [SETUP] Menu.

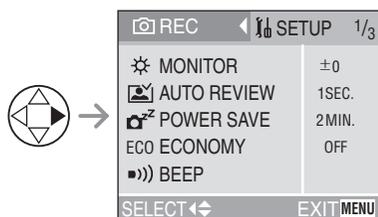

- To forward or reverse the menu screen rotate the zoom lever (A) toward T or W.

### 4 Select the desired item.

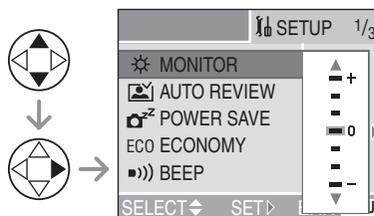

### 5 Select the desired value.

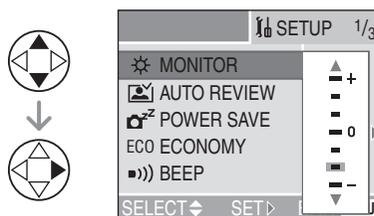

**Be sure to press ► at the end to store the setting.**

- Close the menu by pressing the [MENU] button after finishing the setting. In recording mode, you can also close the menu by pressing the shutter button halfway.

**[SETUP] menu (Refer to P21 for the setting method.)** **[MONITOR]**

Adjust the brightness of the LCD monitor in 7 steps.

- The setting on the brightness of the LCD monitor also affects simple mode [♥].

 **[AUTO REVIEW]**

**[OFF]:** The recorded picture does not automatically appear.

**[1SEC.]:** The recorded picture automatically appears on the screen for about 1 second.

**[3SEC.]:** The recorded picture automatically appears on the screen for about 3 seconds.

**[ZOOM]:** The recorded picture automatically appears on the screen for about 1 second. Then it is enlarged 4 times and appears for about 1 second. This mode is useful for confirming focus. Pictures in auto bracket, burst mode or pictures with audio are not enlarged even if [ZOOM] is selected.

- In motion picture mode [, auto review function is not activated.
- When pictures are recorded in auto bracket [, (P43) or any speed ([, [, [) on burst mode (P45), the auto review function is activated regardless of the setting on the auto review function. (The picture is not enlarged.)
- The auto review function is activated while pictures with audio are recorded regardless of the setting on the auto review function. (The picture is not enlarged.)
- The setting for the auto review function is disabled in auto bracket, burst mode, motion picture mode, [SELF PORTRAIT] (P64) in scene mode, or when [AUDIO REC.] is set to [ON].

 **[POWER SAVE]**

**[1MIN.]/[2MIN.]/[5MIN.]/[10MIN.]:**

The power save mode is activated (the camera is automatically turned off to save the battery life) if the camera has not been used for the time selected on the setting.

**[OFF]:** The power save mode is not activated.

- Press the shutter button halfway or turn the camera off and on to cancel the power save mode.
- When using the AC adaptor (DMW-AC5; optional)/connecting to a PC or a printer/recording motion pictures/playing back motion pictures/during Slide Show, the power save mode is not activated. (However, during a manual Slide Show, the setting for the power save mode is fixed to [10MIN.]
- The setting for power save mode is fixed to [2MIN.] during the following.
  - When economy mode is set
  - In simple mode [♥]

**[SETUP] menu (Refer to P21 for the setting method.)****ECO [ECONOMY]**

The brightness of the LCD monitor is reduced, and the battery life is saved by turning off the LCD monitor automatically while the camera is not in use in the recording mode. (Press any button to recover from the economy mode.)

**[LEVEL 1]:** If you do not operate the camera for about 15 seconds in the recording mode, the LCD monitor is turned off.

**[LEVEL 2]:** If you do not operate the camera for about 15 seconds in the recording mode, or if you do not operate the camera for about 5 seconds after you take a picture, the LCD monitor is turned off.

**[OFF]:** Economy mode cannot be activated.

- **In the economy mode, the LCD monitor is turned off while the flash is being charged.**
- The status indicator lights while the LCD monitor is turned off.
- In the economy mode, [POWER SAVE] is fixed to [2MIN.].
- Economy mode will not work in simple mode [♥] when the menu screen is displayed, the self-timer is set, recording motion pictures or using the AC adaptor (DMW-AC5; optional).
- The brightness of the LCD monitor is not reduced when the power LCD function is activated.

**■))) [BEEP]****■))) [BEEP LEVEL]:**

[X] : No operational sound

[r] : Soft operational sound

[r]) : Loud operational sound

») [BEEP TONE]: ») ① ») ② ») ③

») [SHUTTER]: ») ① ») ② ») ③

- The settings on [BEEP] also affect simple mode [♥].

**[r]) [VOLUME]**

The volume of speakers can be adjusted in 7 steps. (LEVEL 6 to 0)

- When you connect the camera to a TV, the volume of the speakers of the TV is not changed.

**⌚ [CLOCK SET]**

Change date and time. (P20)

**🗑️ [NO.RESET]**

Set this when you want to start the file number of the picture from 0001 on the next recording. (The folder number is updated, and the file number starts from 0001.)

- The folder number can be assigned from 100 to 999.

When the folder number reaches 999, you cannot reset the file number. We recommend formatting the card after saving the data on a PC or elsewhere.

- To reset the folder number to 100, format the card first and then use this function to reset the file number.

After that, the reset screen for the folder number appears. Select [YES] to reset the folder number.

- Refer to P95 for detailed information about the file number and the folder number.

- The file number reset also affects simple mode [♥].

**[SETUP] menu (Refer to P21 for the setting method.)**** [RESET]**

The settings on the [REC] or the [SETUP] menu are reset to the initial settings.

- The birthday setting for [BABY] (P60) in scene mode is also reset when the settings in the [SETUP] menu are reset.
- [ROTATE DISP.] (P81) in the [PLAY] mode menu is also reset to [ON].
- The folder number and the clock setting are not changed.

** [USB MODE]**

Set the USB communication system.

- Set before connecting to a PC or a printer. (P93)

** [VIDEO OUT]**

**(Playback mode only)** (P92)

- [NTSC]:** Video output is set to NTSC system.
- [PAL]:** Video output is set to PAL system.

** [SCENE MENU]**

**[AUTO]:** [SCENE MODE] menu appears automatically when setting the mode dial to scene mode. Select the desired scene mode.

**[OFF]:** [SCENE MODE] menu does not appear when setting the mode dial to scene mode and the camera is operated in scene mode currently selected. If you change the scene mode, press the [MENU] button to display the [SCENE MODE] menu and then select the desired scene mode.

** [LANGUAGE]**

Set to the language on the menu screen from the following languages.

Set to the desired language with ▲/▼ and store it with ►.

- [ENGLISH]:** English
- [DEUTSCH]:** German
- [FRANÇAIS]:** French
- [ESPAÑOL]:** Spanish
- [ITALIANO]:** Italian

**[中文]:** Chinese (Traditional)

**[日本語]:** Japanese

- When you set to other language by mistake, select [  ] from the menu icons to set the desired language.
- The language setting also affects simple mode [  ].

## About the LCD Monitor

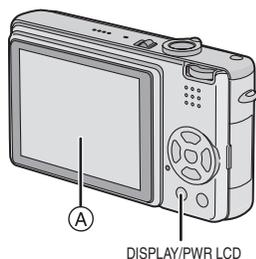

Ⓐ LCD monitor (LCD)

**Press the [DISPLAY] button to change the display.**

- When the menu screen appears, the [DISPLAY] button is not activated. During multi playback (P48) or playback zoom (P50), the indications on the screen can be turned on and off.

**In simple mode [♥] (P33)**

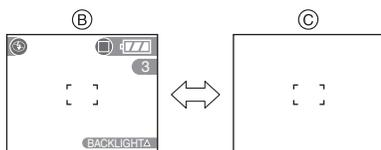

Ⓑ Normal display  
Ⓒ No display

**In recording mode (P29)**

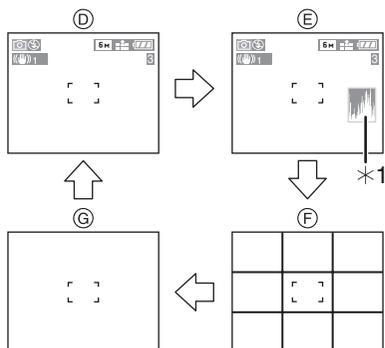

Ⓓ Normal display  
Ⓔ Display with histogram  
Ⓕ No display (Recording guide line)  
Ⓖ No display  
\*1 Histogram

**In playback mode (P47)**

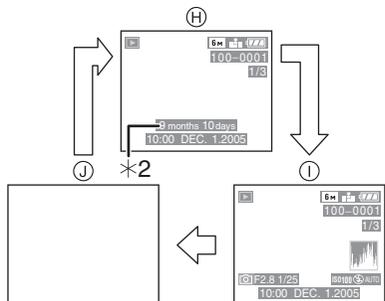

Ⓗ Normal display  
Ⓘ Display with recorded information and histogram  
Ⓙ No display  
\*2 Displayed when you set birthday setting for [BABY] (P60) in scene mode, and [WITH AGE] is selected at taking pictures.

Preparation

■ **To view the LCD monitor outdoors on a bright sunny day (Power LCD function)**

When you press and hold the [PWR LCD] button for 1 second, the power LCD function is activated. The LCD monitor becomes brighter than usual and easier to see outdoors.

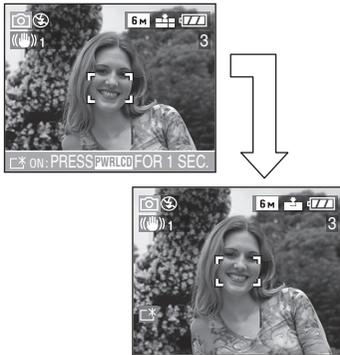

■ **Recording guide line**

When you align the subject on the horizontal and vertical guide lines or the cross point of these lines, you can take pictures with well-designed composition by viewing the size, the slope and the balance of the subject.



- The power LCD icon [  ] appears on the screen.
- When you take pictures, the LCD monitor automatically reverts back to the normal brightness 30 seconds after the [PWR LCD] button is pressed. If you press any button, the LCD monitor turns on brightly again.
- If you press and hold [PWR LCD] button for 1 second again, the power LCD function is canceled and the LCD monitor reverts back to its usual brightness.
- In the power LCD function, the brightness and color tone are emphatically displayed on the LCD monitor. Therefore, the brightness and the color tone may look different from those in real life depending on the subject. However, this function does not affect recorded pictures.

## ■ Histogram

- A histogram is a graph that displays brightness along the horizontal axis (black to white) and the number of pixels at each brightness level on the vertical axis.
  - It allows the camera user to easily check the way a picture is being exposed.
  - It is very useful if manual adjustments of the lens aperture and shutter speed are available, especially in those situations where automatic exposure may be difficult due to uneven lighting. Using the histogram feature will allow you to get the best performance from the camera.
- (A) When the values are concentrated to the left, the picture is under exposed.
- (B) When the values in the histogram are distributed evenly, the exposure is adequate and the brightness is well-balanced.
- (C) When the values are concentrated to the right, the picture is over exposed.

## Example of histogram

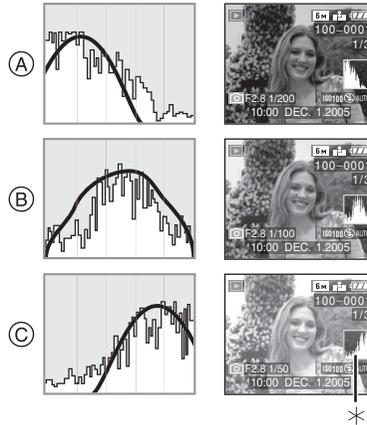

- (A) Under Exposed  
 (B) Properly Exposed  
 (C) Over Exposed  
 \*Histogram



- **When you take pictures with the flash or in dark places, the histogram is displayed in orange because the recorded picture and the histogram do not match each other.**

- The histogram does not appear when in simple mode [♥], motion picture mode [RE], during multi playback and playback zoom.
- The histogram in the recording mode is an approximation.
- The histogram in recording and playback may not match each other.
- The histogram in the camera does not match the one displayed in picture editing software used with a PC, etc.

## Taking Pictures

---

### ■ The Mode Dial

This camera has a mode dial to suit recording of many kinds of scenes. Select the desired mode and enjoy the variety of recording. Rotate it slowly and securely to adjust to each mode.

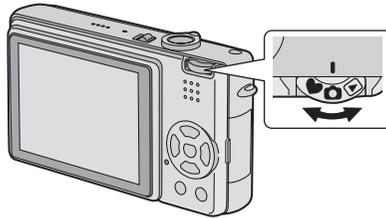

 : **Normal picture mode (P29)**

Use this mode for usual recording.

 : **Simple mode (P33)**

This is the recommended mode for beginners.

 : **Macro mode (P53)**

This mode allows you to take a picture closely focusing on the subject.

 : **Scene mode (P56)**

This mode allows you to take pictures depending on the recording scenes.

 : **Motion picture mode (P53)**

This mode allows you to record motion pictures with audio.

 : **Playback mode (P47)**

This mode allows you to play back recorded pictures.

■ Normal recording



The camera automatically sets the shutter speed and the aperture value according to the brightness of the subject.

- 1 **Turn the camera on.**
- 2 **Select normal picture mode** [ ].

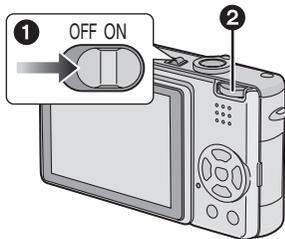

- 2 **Aim the AF area ① to the point you want to focus and then press the shutter button halfway.**

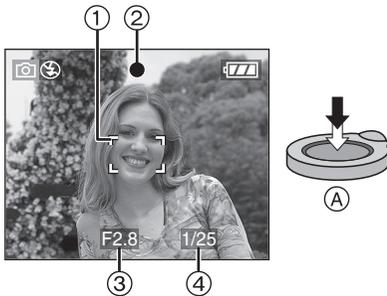

- **(A)**: Press the shutter button halfway to focus.
- The focus indication **②** is lit and then the aperture value **③** and the shutter speed **④** are displayed.
- When 5-area-focusing or 3-area-focusing (High speed) is used for AF mode, the AF area will not appear until the subject is brought into focus. (P73)

**3 Take a picture.**

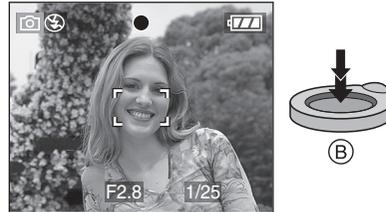

- **(B)**: Press the shutter button fully to take the picture.

	When the subject is not focused	When the subject is focused
Focus indication	Blink (green)	On (green)
AF area	White to red or no AF area	Turns from white to green
Sound	Beeps 4 times	Beeps 2 times

■ **When you want to take a subject out of the AF area (AF/AE Lock)**

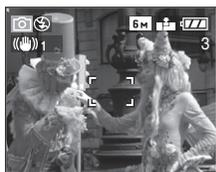

When recording a picture of people with a composition as the above picture, you cannot focus on the subject because it is out of AF area in usual operation.

In this case,

- 1 Aim the AF area at the subject.
  - 2 **Press the shutter button halfway** to fix the focus and the exposure.
    - When the subject is focused, the focus indication lights.
  - 3 **Keeping pressed the shutter button halfway**, move the camera as you compose the picture.
  - 4 Press the shutter button fully.
- You can repeatedly retry AF/AE lock before pressing the shutter button fully.

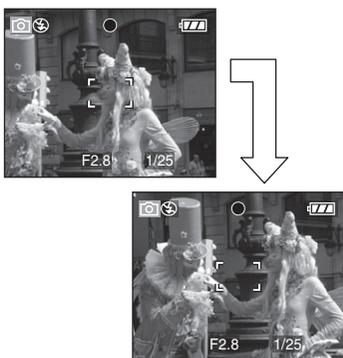

■ **Tips for taking good pictures**

To take pictures without blurring:

- Hold the camera gently with both hands, keep arms stationary at your side and stand with your feet slightly apart.
- Make sure that camera shake does not occur when you press the shutter button.
- Do not cover the photo flash or the AF assist lamp with your finger or other objects.
- Do not touch the front of the lens.

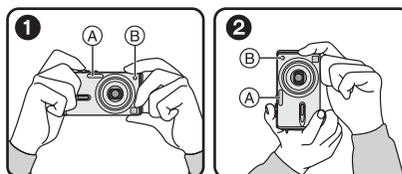

❶: When holding the camera sideways

❷: When holding the camera vertically

Ⓐ: Photo flash

Ⓑ: AF assist lamp

• Especially in the following cases, the shutter speed will be slower. Keep the camera still from the moment you press the shutter button until the picture appears on the screen. We recommend using a tripod. The use of the self-timer (P41) prevents jittering caused by pressing the shutter button when you are using a tripod.

- Slow sync./Red-eye reduction [⚡S👁] (P38)
- [NIGHT PORTRAIT] (P59)
- [NIGHT SCENERY] (P59)
- [CANDLE LIGHT] (P61)
- [PARTY] (P62)
- [FIREWORKS] (P62)
- [STARRY SKY] (P63)
- When the shutter speed is slowed in [SLOW SHUTTER] (P75)

### ■ Focusing

- The focus range is 50 cm (1.64 feet) to  $\infty$ .
  - When you press the shutter button fully with one stroke, pictures may be blurry or unfocused.
  - When the focus indication is blinking, the subject is not focused. Press the shutter button halfway and focus on the subject again.
  - If the camera will not focus after a few tries, turn it off and on and try again.
  - In the following cases, the camera will not focus on subjects properly.
    - When including both near and distant subjects in a scene.
    - When there is dirt or dust on the glass between the lens and the subject.
    - When there are illuminated or glittering objects around the subject.
    - When taking a picture in a dark place.
    - When the subject is moving fast.
    - When the scene has low contrast.
    - When jitter occurs.
    - When recording a very bright subject.
- We recommend taking pictures using AF/AE lock (P30). In dark places, the AF assist lamp (P74) may turn on to focus on the subject.
- Even if the focus indication appears and the subject is focused, it is canceled when you release the shutter button. Press the shutter button halfway again.

### ■ Jitter (camera shake)

- Be careful of jittering when pressing the shutter button, especially when fully zoomed into the subject.
- When jitter could occur because of slow shutter speed, the jitter alert (A) appears.

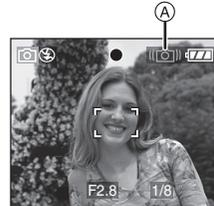

- When the jitter alert appears, we recommend using a tripod. If you cannot use a tripod, be careful of how you hold the camera (P30). The use of the self-timer (P41) prevents jittering caused by pressing the shutter button when you are using a tripod.

### ■ Direction detection function

- If you take pictures by holding the camera vertically, the information of the rotation on the pictures is automatically added and recorded to the pictures. When [ROTATE DISP.] (P81) is set to [ON], you can rotate and display pictures on the screen or the TV according to the information of the rotation on the pictures.
- When you take pictures by holding the camera vertically, read "Tips for taking good pictures" on P30 carefully.
- This function may not work properly on pictures recorded by aiming the camera up or down.
- In motion picture mode [MOVIE], you cannot use the direction detection function.

## ■ Exposure

- If you press the shutter button halfway when the exposure is not adequate, the indication of the aperture value and the shutter speed turns red. (However, the aperture value and the shutter speed do not turn red when the flash is activated.)
  - The brightness of the LCD monitor may differ from that of recorded pictures. The subject looks dark on the LCD monitor, but the actual picture is bright.
  - When most of the subjects in the screen are bright (e.g. blue sky on a clear day, snowy field, etc.), the recorded pictures may become dark. In this case, compensate the exposure value on the camera. (P42)
-  - - - - -
- When you press the shutter button, the LCD monitor may become bright or dark for a moment. This function allows easy adjustment of focus and the recorded picture will not be affected.
  - We recommend making sure the clock is set properly before taking pictures. (P20)
  - When the time for power save is set (P22), the camera is automatically turned off if you do not operate within the set time. When operating the camera again, press the shutter button halfway or turn the camera off and on.
  - In some cases, if the distance between the camera and the subject is beyond the recordable range when you use the camera, the picture may not be properly focused even if the focus indication is lit.

## Taking Pictures in Simple Mode



This mode allows beginners to take pictures easily. Only the most basic functions appear in the menu to make operations simple.

### 1 Select the desired item and set the desired value.

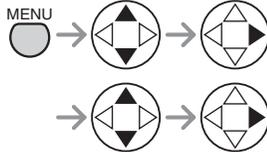
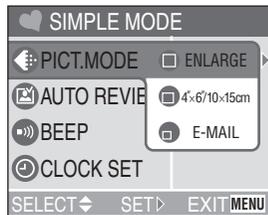

- Close the menu by pressing the shutter button halfway or the [MENU] button after finishing the setting.

### ■ Settings in Simple mode

#### [PICT.MODE]

 ENLARGE	Optimum for enlarging to 8"×10", Letter etc.
 4"×6"/10×15cm	Optimum for regular size printing.
 E-MAIL	Optimum for attaching to e-mails or insertion into website.

#### [AUTO REVIEW]

 OFF	OFF	The recorded picture does not automatically appear.
 ON	ON	The recorded picture automatically appears on the screen for about 1 second.

#### [BEEP]

 OFF	OFF	No operational sound
 LOW	LOW	Soft operational sound
 HIGH	HIGH	Loud operational sound

#### [CLOCK SET]

Change date and time. (P20)

Recording pictures (basic)

■ Other Settings in Simple mode

In Simple mode, other settings are fixed as follows. For details, refer to the pages corresponding to each item.

Focus range	30 cm (0.98 feet) to ∞ (Tele) 5 cm (0.16 feet) to ∞ (Wide)	
[POWER SAVE]	[2MIN.]	P22
[ECONOMY]	[OFF]	P23
Self-timer	10 seconds	P41
Optical Image Stabilizer	[MODE2]	P44
Burst speed	Low speed Number of recordable pictures in burst mode • [ENLARGE]: max. 6 pictures • [4"×6"/10×15cm]: max. 8 pictures • [E-MAIL]: max. 8 pictures	P45
[W.BALANCE]	[AUTO]	P67
[SENSITIVITY]	[AUTO]	P69
[ASPECT RATIO]	[4:3]	P69
[PICT.SIZE] and [QUALITY]	• [ENLARGE]: <input type="checkbox"/> 6M (6M)/Fine • [4"×6"/10×15cm]: <input type="checkbox"/> 2M (2M EZ)/Standard • [E-MAIL]: <input type="checkbox"/> 0.3M (0.3M EZ)/Standard	P70 P72
[AF MODE]	[ <input type="checkbox"/> ] (1-area-focusing)	P73
[AF ASSIST LAMP]	[ON]	P74
[SLOW SHUTTER]	[1/8-]	P75

### ■ The Backlight Compensation

Backlight is a situation where light comes from the back of subjects. Subjects such as people become dark when pictures are recorded in backlight. If you press ▲, [BACK] (compensating backlight ON indication) appears and the backlight compensation function is activated. This function compensates the backlight by brightening the whole of the picture.



- If you press ▲ while [BACK] is displayed, [BACK] disappears and the backlight compensation function is canceled.
- When you use the backlight compensation function, we recommend using the flash.



- With [4"×6"/10×15cm] or [E-MAIL] in [PICT.MODE], the extended optical zoom is activated and the zoom ratio is extended to a maximum of 4.1×. (P71)
- The settings on the simple mode are not applied to other recording modes except [CLOCK SET] and [BEEP].
- The setting on [MONITOR] (P22), [BEEP TONE] (P23), [SHUTTER] (P23), [NO.RESET] (P23) and [LANGUAGE] (P24) in the [SETUP] menu also affects the simple mode.
- You cannot use the following functions in the simple mode.
  - White balance fine adjustment
  - Exposure compensation
  - Auto bracket
  - [AUDIO REC.]
  - [D.ZOOM]
  - [COL.EFFECT]
  - [PICT.ADJ.]

## Checking the Recorded Picture (Review)



### 1 Press ▼ [REV].



- The last recorded picture appears for about 10 seconds.
- Review is canceled when the shutter button is pressed halfway or the [REV] button is pressed again.
- You can check other pictures by pressing ◀▶.
- When the recorded pictures are too bright or dim, compensate the exposure. (P42)

### 2 Enlarge and shift the picture.

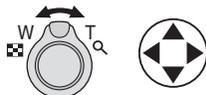

- Q : 1x → 4x → 8x
- : 8x → 4x → 1x

- When you change the magnification or the position to be displayed, the zoom position indication (A) appears for about 1 second to check the enlarged area.

### Recorded pictures can be deleted during the review (Quick Deletion)



- Once deleted, pictures cannot be recovered.
- Multi pictures or all pictures can be deleted. Read P51 to operate them.

## Using the Optical Zoom



You can make people and subjects appear closer with the 3 times optical zoom, and landscapes can be recorded in wide angle.

### ■ To make subjects appear closer use (Tele)

When the picture size setting is [**6M**] (6M).

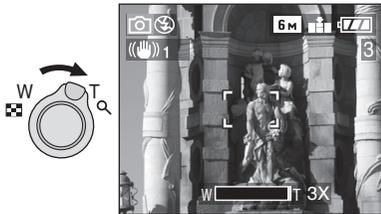

### ■ To make subjects appear further away use (Wide)

When the picture size setting is [**6M**] (6M).

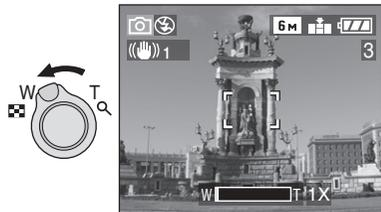

- The optical zoom is set to Wide (1×) when the camera is turned on.
- The picture may have some distortion (typical example: vertical straight line bent outwards). This is due to the lens aberration, which is common to some extent with all photographic lenses. Distortion may be more visible when using a wider area of the zoom lens as you get closer to the subject.
- When using the zoom lens at high magnification, the quality of the picture can be enhanced if a tripod is used. At high magnification, even small movements can cause a slight decrease in picture sharpness.
- If you use the zoom function after focusing on the subject, focus on the subject again.
- In motion picture mode [**H**], the zoom magnification is fixed to the value set at the start of recording.
- The indicated zoom magnification is an approximation.
- The lens barrel (P11) is ejected or retracted according to the zoom position.
- Take care not to interrupt the motion of the lens barrel while the zoom lever is rotated.

### ■ Taking pictures using the extended optical zoom (EZ)

If the picture size is set to [**3M**] (3M EZ) etc., the zoom ratio is extended to a maximum of 4.1× when the digital zoom is set to [OFF]. This allows subjects to be recorded at an even higher magnification. (P71)

### ■ Taking pictures using digital zoom

When you set [D.ZOOM] in the [REC] mode menu to [ON], you can use the digital zoom to take even closer pictures. (P75)

## Taking Pictures using the Built-in Flash



When you set the flash, you can take pictures using the built-in flash according to the recording condition.

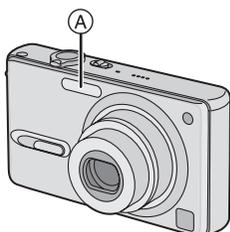

### A: Photo flash

Do not cover it with your finger or any other items.

### Switching to the appropriate flash setting

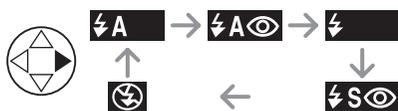

For the selectable flash settings, refer to “Available flash settings by recording mode” on P39.

### ⚡A: AUTO

The flash is automatically activated according to the recording condition.

### ⚡A👁️: AUTO/Red-eye reduction

The flash is automatically activated according to the recording condition. It reduces the red-eye phenomenon (eyes of the subject appear red in the picture) by triggering the flash before actually recording the picture. After that, the flash is activated for actual recording again.

- The flash is activated twice. The first flash is activated only for a preparation of actual recording. The subject should not move until the second flash is finished.
- Use this when you take pictures of people in low lighting conditions.

### ⚡: Forced ON

The flash is activated every time regardless of the recording condition.

- Use this when your subject is back-lit or under fluorescent light.

### ⚡👁️: Forced ON/Red-eye reduction

- The flash setting is set to Forced ON/Red-eye reduction only when you set [CANDLE LIGHT] (P61) or [PARTY] (P62) in scene mode.

### ⚡S👁️: Slow sync./Red-eye reduction

When you take a picture with a dark background landscape, this feature makes the shutter speed slow when the flash is activated, so that the dark background landscape will become bright. Simultaneously it reduces the red-eye phenomenon.

- Use this when you take pictures of people in front of a dark background.

### 🚫: Forced OFF

The flash is not activated in any recording condition.

- Use this when you take pictures in places where the use of the flash is not permitted.

Recording pictures (basic)

■ Available flash settings by recording mode

The available flash settings depend on the recording mode.

(○: Available, —: Not available)

	○	—	○	○	○	○	—	—	—	○	○	—	—	—	○	—	○	—
	○	○*	○	○	○	—	—	—	—	○	○	—	—	—	—	—	○	—
	○	○	○	○	○	○	—	—	—	○	○	—	—	—	○	—	○	—
	○	—	○	—	—	—	—	○	—	—	—	○	○	—	—	—	—	—
	—	—	—	—	—	—	—	—	—	—	○	○	—	—	—	—	—	—
	○	○	○	○	○	○	○	○	○	○	○	○	○	○	○	○	○	○

\*Not available in backlight compensation

■ The available flash range to take pictures

ISO sensitivity	Available flash control range	
	Wide	Tele
AUTO	30 cm (0.98 feet) to 4.0 m (13.1 feet)	30 cm (0.98 feet) to 2.2 m (7.22 feet)
ISO80	30 cm (0.98 feet) to 1.7 m (5.58 feet)	30 cm (0.98 feet) to 1.0 m (3.28 feet)
ISO100	30 cm (0.98 feet) to 2.0 m (6.56 feet)	30 cm (0.98 feet) to 1.1 m (3.61 feet)
ISO200	40 cm (1.31 feet) to 2.8 m (9.19 feet)	30 cm (0.98 feet) to 1.5 m (4.92 feet)
ISO400	60 cm (1.97 feet) to 4.0 m (13.1 feet)	40 cm (1.31 feet) to 2.2 m (7.22 feet)

- The available flash range is an approximation.
- Refer to P31 for the focus range.
- Refer to P69 for the ISO sensitivity.
- If the ISO sensitivity is set to [AUTO] when using the flash, it will be automatically increased to a maximum of [ISO400].
- To avoid noise, we recommend decreasing the ISO sensitivity (P69) or setting [PICT.ADJ.] to [NATURAL]. (P76)

### ■ Shutter speed for each flash setting

Flash setting	Shutter speed (Sec)
 : AUTO	1/60 to 1/2000
 : AUTO/Red-eye reduction	1/60 to 1/2000
 : Forced ON	1/60 to 1/2000
 : Forced ON/Red-eye reduction	
 : Slow sync./Red-eye reduction	1/8* to 1/2000
 : Forced OFF	1/8* to 1/2000

\*The shutter speed changes depending on the slow shutter setting. (P75)

- There may be differences in the above shutter speeds in scene mode.
  - [NIGHT SCENERY] mode: 8 to 1/2000th
  - [BABY] mode (when using the flash): 1/30th to 1/2000th
  - [STARRY SKY] mode: 15 seconds, 30 seconds, 60 seconds



- **Do not stare at the photo flash from close proximity.**
- **If you bring the flash too close to the subjects, they may be distorted or discolored by its heat and lighting.**
- **Do not cover the photo flash with your fingers or any other items.**
- **While the flash is being charged in economy mode, the LCD monitor is turned off.**
- The flash icon turns red when activating the flash and pressing the shutter button halfway.
- When you take a picture beyond the flash control range, the exposure may not be adjusted properly and the picture may become bright or dark.
- When you repeat taking a picture, recording may be disabled even if the flash is activated. Take a picture after the access indication disappears.
- When the jitter alert appears, we recommend using the flash.
- When you set to burst mode or auto bracket, only 1 picture is recorded for every flash activated.
- When the flash is being charged, the flash icon blinks red, and you cannot take a picture even when you press the shutter button fully.
- When taking a picture with the flash, the white balance will be automatically adjusted [except for [  ] (Daylight)], but the white balance may not be properly adjusted if the flash level is insufficient.
- When the shutter speed is fast, the flash effect may not be sufficient.

## Taking Pictures with the Self-timer



### 1 Select the self-timer mode.



: Self-timer set to 10 seconds

: Self-timer set to 2 seconds

No display: canceled

### 2 Take the picture.

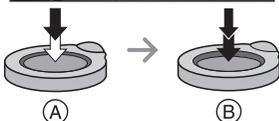

- (A): Press the shutter button halfway to focus.
- (B): Press the shutter button fully to take the picture.

- The self-timer indicator

blinks and the shutter is activated after 10 seconds (or 2 seconds).

- If you press the [MENU] button when the self-timer is set, the self-timer setting is canceled.

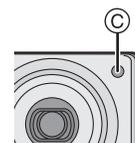

- When using a tripod or in other cases, setting the self-timer to 2 seconds is a convenient way to avoid the jitter caused by pressing the shutter button.
- When you press the shutter button fully with one stroke, the subject is automatically focused just before the recording. In dark places, the self-timer indicator blinks and then it may turn on brightly to work as the AF assist lamp (P74) for focusing on the subject.
- In simple mode [], the self-timer is fixed to 10 seconds.
- In [SELF PORTRAIT] (P64) in scene mode, the self-timer is fixed to 2 seconds.
- When you set the self-timer in the burst mode, the camera starts taking a picture 2 or 10 seconds after the shutter button is pressed. The number of pictures taken at a time is fixed to 3.
- We recommend using a tripod when recording with the self-timer. (When you use a tripod, make sure the tripod is stable when the camera is attached to it.)

## Compensating the Exposure



Use this function when you cannot achieve appropriate exposure due to the difference of brightness between the subject and the background. Check the following for examples.

### Under exposed



Compensate the exposure toward positive.



### Properly exposed



### Over exposed



Compensate the exposure toward negative.

1 Press **▲** [] several times until [] **EXPOSURE** appears and then compensate the exposure.



- You can compensate from  $-2$  EV to  $+2$  EV in steps of  $1/3$  EV.



- EV is an abbreviation for Exposure Value, and it is the amount of light given to the CCD by the aperture value and the shutter speed.
- The compensation range of the exposure will be limited depending on the brightness of the subject.
- The exposure compensation value appears on the lower left of the screen.
- The set exposure value is memorized even if the camera is turned off.
- Exposure cannot be compensated when using [STARRY SKY] (P63) in scene mode.

## Taking Pictures using Auto Bracket



In this mode, 3 pictures are automatically recorded by each press of the shutter button according to the compensation range of the exposure.

You can select the desired exposure among the 3 types of pictures.

**1 Press  $\blacktriangle$  [] several times until [] AUTO BRACKET] appears and then set the compensation range of the exposure.**

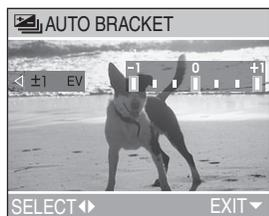

- You can select the exposure from  $-1$  EV to  $+1$  EV in steps of  $1/3$  EV.
- When you do not use auto bracket, select [OFF].
- When setting the auto bracket, the auto bracket icon appears on the lower left of the screen.



- If the remaining number of recordable pictures is 2 or less, you cannot take pictures by setting auto bracket.
- When taking pictures using auto bracket after the exposure compensation, the pictures are based on the compensated exposure.
  - When the exposure is compensated, the compensated exposure value appears on the lower left of the screen.
- When the flash is activated or [STARRY SKY] (P63) in scene mode is selected, you can take only 1 picture.
- When the auto bracket is activated, [AUDIO REC.] cannot be used.
- When setting auto bracket and the burst mode simultaneously, auto bracket will be performed.
- The exposure may not be compensated with auto bracket depending on the brightness of the subject.
- Auto bracket is canceled after switching the camera off.
- When setting the auto bracket, the auto review function is activated regardless of the setting on the auto review function. (The picture is not enlarged.) Moreover, the settings for the auto review function on the [SETUP] menu are disabled.

## Optical Image Stabilizer



This mode recognizes and compensates jitter. You can reduce blurring caused by jitter especially when you take pictures with the optical zoom set to Tele or when you take pictures indoors where the shutter speed is slowed down.

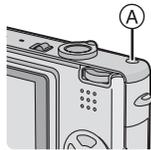

**1 Press and hold the optical image stabilizer button (A) until [STABILIZER] appears and then select the stabilizer function mode.**

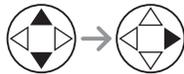
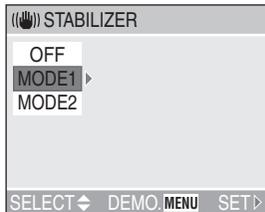

MODE1 (  )	The stabilizer operates continuously and can assist during photo composition.
MODE2 (  )	The stabilizer function is in standby and activates at the moment the shutter captures the image.
OFF (  )	When image stabilization is not needed or when using the camera with a tripod.

### ■ Demonstration of the optical image stabilizer (Demonstration Mode)

When you press the [MENU] button, the demonstration appears. After the demonstration ends, the screen returns to the stabilizer function mode selection menu. If you want to exit the demonstration halfway through, press the [MENU] button again.

While the demonstration is displayed, the optical zoom is fixed to Wide (1×) and the zoom function cannot be activated. Moreover, you cannot take pictures.



The stabilizer function may not work sufficiently in the following cases.

- When too much jitter occurs.
- In digital zoom range.
- When taking pictures while following subjects in motion.
- When the shutter speed is extremely slow due to dark conditions or other reasons.

Be careful of jittering when pressing the shutter button.

- In simple mode [] or [SELF PORTRAIT] (P64) in scene mode, the setting is fixed to [MODE2] and in [STARRY SKY] (P63) it is fixed to [OFF]. The stabilizer function menu does not appear.
- In motion picture mode [>], [MODE2] cannot be set.

## Taking Pictures using Burst Mode



1 Press the single or burst mode button to switch the burst mode setting and then take pictures.

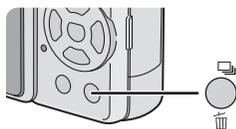
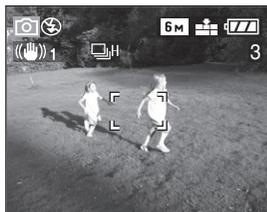

: High speed

↓  
 : Low speed

↓  
 : Unlimited\*1

↓  
No display: canceled

\*1 Depending on the memory size, battery power, picture size and quality (compression)

- Hold down the shutter button fully to activate the burst mode.

### ■ Number of pictures recorded in burst mode

	Burst speed (pictures/second)	Number of recordable pictures (pictures)	
	3*2	max. 6	max. 8
	2*2	max. 6	max. 8
	approx. 1.5	Depends on remaining capacity of the card	

\*2 The burst speed is constant regardless of the transfer speed of the card.

- When the shutter speed is faster than 1/60 and the flash is not activated.



### • When the burst mode setting is set to Unlimited

- You can take pictures until the capacity of the card becomes full.
- The burst speed becomes slower halfway. Depending on the picture size or card, the speed differs.
- The focus is fixed at taking the first picture.
- In simple mode [], the burst speed is fixed to Low.
- When the self-timer is used, the number of recordable pictures in burst mode is fixed to 3.
- When the burst mode is activated, [AUDIO REC.] cannot be used.
- When the flash is activated or [STARRY SKY] (P63) in scene mode is selected, you can take only 1 picture.
- When setting auto bracket and the burst mode simultaneously, auto bracket will be performed.

*Recording pictures (basic)*

- The ways to control the exposure and the white balance vary depending on the burst mode setting. When the burst mode is set to [ ] or [ ], they are fixed to the values set for the first picture. When the burst speed is set to [ ], they are adjusted each time you take a picture.
- When setting the burst mode, the auto review function is activated regardless of the setting on the auto review function. (The picture is not enlarged.) Moreover, the settings for the auto review function on the [SETUP] menu are disabled.
- Burst mode is not canceled when the camera is switched off.
- Burst mode will not perform as described if a MultiMediaCard is used in place of an SD Memory Card. The reading/writing speed of a MultiMediaCard is slower than that of an SD Memory Card.

## Playing Back Pictures



### 1 Select the picture.

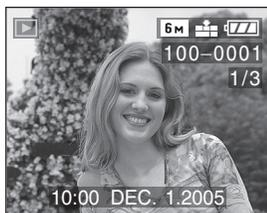

- ◀: Play back the previous picture.
- ▶: Play back the next picture.
- The last recorded picture will be played back first.
- When [ROTATE DISP.] (P81) is set to [ON], pictures recorded by holding the camera vertically are played back vertically.



### ■ Fast forwarding/Fast rewinding

When you keep pressing ◀/▶ during playback, the file number and the page number are updated. If you release ◀/▶ when the number of the desired picture appears, you can play back the picture.

- ▶: Fast forward
- ◀: Fast rewind

- When you keep pressing ◀/▶, the number of files forwarded/rewound at a time is increased.
- If you release ◀/▶ and press them again, the files will be forwarded/rewound one by one.
- In review playback in the recording mode or multi playback, the picture can only be forwarded or rewound one by one.
- When you forward or rewind a large number of pictures, release ◀/▶ once before reaching the picture to be played back, then press ◀/▶ to forward/rewind pictures little by little.



- This camera is based on the DCF standard (Design rule for Camera File system) which was established by the Japan Electronics and Information Technology Industries Association (JEITA).
- When changing the folder name or file name on a PC, the pictures will not be played back.
- The file format that can be played back with the camera is JPEG. (Even JPEG pictures cannot be played back in some cases.)
- When playing back pictures that have been recorded with other equipment, the picture quality may deteriorate or the pictures may not play back.
- When playing back a non-standard file, the folder/file number is indicated by [—] and the screen may turn black.
- An interference fringe may appear on the screen depending on the subject. This is called moire. This is not a malfunction.

## Multi Playback

(9 screens, 16 screens, and 25 screens)



### 1 Rotate the zoom lever towards [W] [T] to display multiple pictures.

(Screen when 9 screens are displayed)

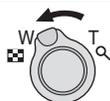

- [W] [T]: 1 screen → 9 screens → 16 screens → 25 screens
- After switching to multiple screen, rotate the zoom lever further towards [W] [T] to display 16 screens then 25 screens. Rotate the zoom lever towards [Q] [T] to return to the previous screen.
- When you switch to multi screen, the scroll bar **A** appears. From all the recorded pictures, the location of the displayed picture can be confirmed.

### 2 Select the pictures.



- The selected picture's recording date and number, the total number of recorded pictures, [★] a favorites (only when [FAVORITE] (P80) has been set to [ON]), [M] a motion picture, [B] in [BABY] in scene mode, age in months, age in years etc. are displayed.

### Examples of 16 screens and 25 screens



- **B**: 16 screens
- **C**: 25 screens

■ **To return to the normal playback**

Rotate the zoom lever towards [Q] [T] or press the [MENU] button.

- The picture framed in orange appears.

■ **To delete a picture during a multi playback**

Press the  button.

When the confirmation screen appears, press ▼ to select [YES], and press ►. (P51)



- Pictures will not be displayed in the rotated direction even if [ROTATE DISP.] is set to [ON]. (P81)
- You can switch whether you turn the indications on the LCD monitor on or off by pressing the [DISPLAY] button.

## Using the Playback Zoom



### 1 Rotate the zoom lever towards [Q] to enlarge the picture.

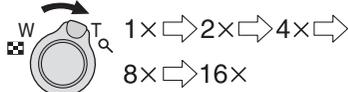
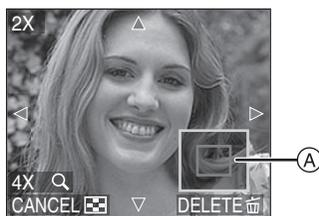

- When you rotate the zoom lever towards [ ] after the picture is enlarged, the magnification becomes lower. When you rotate the zoom lever towards [Q], the magnification becomes higher.
- When you change the magnification, the zoom position indication (A) appears for about 1 second to check the position of the section enlarged.
- When you press the [MENU] button, the magnification reverts to 1x.

### 2 Shift the picture.

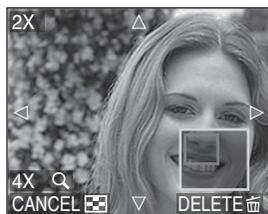

- When you move the position to be displayed, the zoom position indication is displayed for about 1 second.

### ■ To delete a picture during playback zoom

Press the [ ] button.

When the confirmation screen appears, press ▼ to select [YES], and press ►. (P51)



- The more the picture is enlarged, the more its quality deteriorates.
- The playback zoom may not operate if pictures have been recorded with other equipment.
- Even if the indications on the screen are turned off in normal playback mode (P25), the magnification and enabled operations appear on the screen when the playback zoom is activated. You can switch whether you turn the indications on the LCD monitor on or off by pressing the [DISPLAY] button. When you set the magnification to 1x, the indications on the LCD monitor are displayed as in normal playback mode.

## Deleting Pictures



### ■ To delete a single picture

#### 1 Select the picture to be deleted.

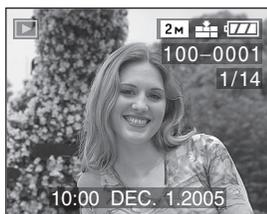

- ◀: Play back the previous picture.
- ▶: Play back the next picture.

#### 2 Delete the picture.



- While deleting the picture, [🗑️] appears on the screen.

### ■ To delete [MULTI DELETE]/ [ALL DELETE]

#### 1 Select [MULTI DELETE] or [ALL DELETE].

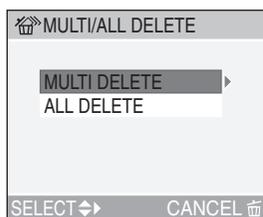

#### 2 times

- If you selected [MULTI DELETE], perform steps 2 and 3. (P52)
- If you selected [ALL DELETE], perform step 3. (P52)

## 2 Select the pictures to be deleted. (Only when selecting [MULTI DELETE])



- Repeat the above procedure.
- The selected pictures appear with . When  $\blacktriangledown$  is pressed again, the setting is canceled.
- After selecting pictures, press to delete.
- The icon blinks red if the selected picture is protected and cannot be deleted. Cancel the protect setting (P85), then delete the picture.

## 3 Delete the pictures. (Screen when selecting [MULTI DELETE])

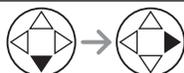

- When using [ALL DELETE], [DELETE ALL PICTURES?] is displayed.



- When [FAVORITE] (P80) is set to [ON], [ALL DELETE EXCEPT  $\star$ ] appears in the [MULTI/ALL DELETE] screen. All the pictures not set as favorites can be deleted if you select [ALL DELETE EXCEPT  $\star$ ] and use the same steps as [ALL DELETE]. However, if none of the pictures have [ $\star$ ] displayed, you cannot select [ALL DELETE EXCEPT  $\star$ ] even if [FAVORITE] is set to [ON].
- Once deleted, pictures cannot be recovered. Please double-check before deleting pictures.
- Do not turn off the camera while deleting.
- When you delete pictures, use a battery with sufficient battery power (P14) or use the AC adaptor (DMW-AC5; optional).
- It is possible to delete up to 50 pictures all at once using [MULTI DELETE].
- More numbers of pictures take longer time for deletion.
- Pictures that are protected (P85) or do not conform to the DCF standard (P47) will not be deleted even if [ALL DELETE] or [ALL DELETE EXCEPT  $\star$ ] is selected.

## Using the Mode Dial

### Macro mode



This mode allows you to take close-up pictures of the subject, e.g. when taking pictures of flowers.

You can take pictures approaching the subject at a distance up to 5 cm (0.16 feet) from the lens by rotating the zoom lever upmost to Wide (1×).

#### ■ Focus range

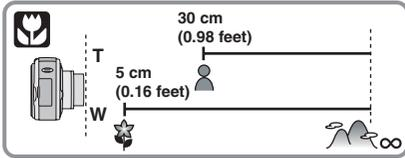

- We recommend using a tripod and the self-timer (P41) in the macro mode.
- When the subject is close to the camera, the effective focus range (depth of field) is significantly narrowed. Therefore, you will have difficulty in focusing on the subject if the distance between the camera and the subject is changed after focusing on the subject.
- When the camera lens is at a distance beyond the available range from the subject, the subject may not be focused even if the focus indication lights.
- The available flash range is about 30 cm (0.98 feet) to 4.0 m (13.1 feet) (Wide). (This is applied when you set the ISO sensitivity to [AUTO].)
- When you take pictures at close range in macro mode, the resolution of the peripheral of the picture may be slightly decreased. However, this is not a malfunction.

### Motion picture mode



This mode allows you to record motion pictures with audio.

#### 1 Select [PICT.MODE].

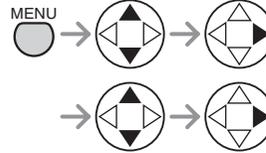
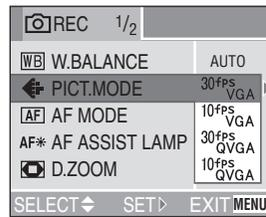

- Close the menu by pressing the shutter button halfway or the [MENU] button after finishing the setting.

	Picture size	fps (frame/second)
30fpsVGA	640×480 pixels	30
10fpsVGA		10
30fpsQVGA	320×240 pixels	30
10fpsQVGA		10

- You can record smoother motion pictures with [30fpsVGA] and [30fpsQVGA].
- You can record motion pictures for longer period with [10fpsVGA] and [10fpsQVGA] although the picture quality is lower.
- Since the file size of [10fpsQVGA] is small, it is suitable for e-mails.
- fps (frame per second); This refers to the number of frames used in 1 second.

## 2 Press the shutter button halfway.

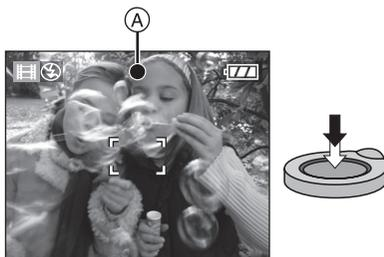

- When the subject is focused, the focus indication **A** lights.

## 3 Press the shutter button fully to start the recording.

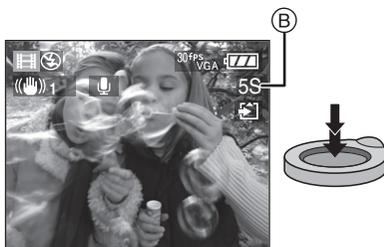

- The remaining recording time **B** (approx.) is displayed.
- The audio recording starts simultaneously from the built-in microphone of the camera.
- By pressing the shutter button fully again, the recording stops.
- If the card becomes full during recording, the camera stops automatically.

### ■ Available recording time (seconds)

SD Memory Card	Picture quality setting			
	30fps VGA	10fps VGA	30fps QVGA	10fps QVGA
16 MB	5	25	25	82
32 MB	16	58	58	175
64 MB	38	120	120	360
128 MB	82	250	250	740
256 MB	160	490	490	1440
512 MB	320	980	980	2870
1 GB	660	1970	1970	5700
2 GB	1350	4020	4020	11700

- The recordable time is an approximation. (It varies depending on the recording condition and the types of SD memory Card.)
- The recording time changes with subjects.
- The available recording time displayed on the LCD monitor may not reduce regularly.
- This unit does not support MultiMediaCard for recording motion pictures.



- **When you set the picture quality to [30fpsVGA], we recommend using a high speed SD Memory Card with “10 MB/s” or greater displayed on the package.**
- **Depending on the type of SD Memory Card and how many times it has been recorded onto or deleted, recording may stop in the middle. If something like this happens, clean-up may be effective. We recommend you clean up the card using the camera in advance. (P90)**
- **We recommend using Panasonic’s SD Memory Card. (Use only genuine SD cards with an SD Logo.)**
- The motion pictures cannot be recorded without audio.
- The settings of auto focus/zoom/aperture values are fixed to what they are when recording starts (in the first frame).
- Depending on the type of card, the card access indication appears for a while after recording motion pictures. However, this is not a malfunction.
- When motion pictures recorded with the camera are played back on other equipment, the quality of pictures and sounds may be deteriorated or it may not be possible to play them back.
- Motion pictures recorded with setting to [30fpsVGA], [30fpsQVGA] or [10fpsVGA] on this camera cannot be played back on equipment which does not support these settings.
- In motion picture mode [, you cannot use the direction detection function and the review function.
- You cannot set [MODE2] on the optical image stabilizer function.
- Please note that the bundled software includes Quicktime to play back motion picture files created with the camera on the PC.

**SCN Scene mode**

Set the mode dial to the scene mode to display the [SCENE MODE] menu. When [SCENE MENU] (P24) on the [SETUP] menu is set to [OFF], press the [MENU] button to display the [SCENE MODE] menu.

Menu items

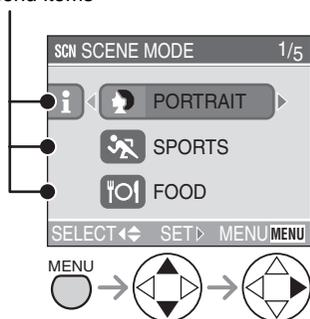

- When you press ◀, the explanations for each scene mode are displayed. (When you press ▶, the screen returns to the [SCENE MODE] menu.)
- When rotating the zoom lever toward T or W, the page of the menu screen can be forwarded or reversed.
- If you press the [MENU] button while the [SCENE MODE] menu is displayed, you can set the [REC] mode menu (P66) and the [SETUP] menu (P21).

- : [PORTRAIT] (P57)
- : [SPORTS] (P57)
- : [FOOD] (P58)
- : [SCENERY] (P58)
- : [NIGHT PORTRAIT] (P59)
- : [NIGHT SCENERY] (P59)
- : [BABY] (P60)
- : [SOFT SKIN] (P61)
- : [CANDLE LIGHT] (P61)
- : [PARTY] (P62)
- : [FIREWORKS] (P62)
- : [SNOW] (P63)
- : [STARRY SKY] (P63)
- : [SELF PORTRAIT] (P64)



- When you take pictures with a scene mode which is not adequate for the purpose, the hue may differ from the actual scene.
- When you want to change the brightness of the picture to be recorded, compensate the exposure (P42). (However, the exposure cannot be compensated in [STARRY SKY].)
- The following functions cannot be set in scene mode.
  - White balance (P67)
  - ISO sensitivity (P69)
  - Color effect (P76)
  - Picture adjustment (P76)

**[SCENE MODE] menu (Refer to P56 for information about how to select the menu.)**

### **Portrait mode**

Select this mode when you want to take pictures of people.

This mode allows you to make the subject stand out from an unfocused background and adjust the exposure and the hue to achieve a healthy complexion on the subject.

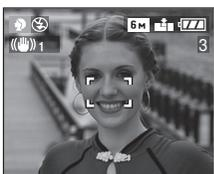

#### ■ **Technique for Portrait mode**

To make this mode more effective:

- 1 Rotate the zoom lever to Tele as far as possible.
- 2 To maximize the effect, select a background as far as possible from the camera, and get closer to the subject.



- This mode is only suitable for outdoors in the daytime.
- The ISO sensitivity is fixed to [AUTO].

### **Sports mode**

This mode allows you to take pictures of a fast moving subject. (e.g. When taking pictures of outdoor sports.)

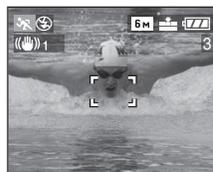

#### ■ **Technique for Sports mode**

To take a sharp picture of a fast moving subject, the shutter speed becomes faster than usual. This mode is more effective when taking pictures in the daytime on a clear day.



- This mode is suitable for outdoors only in the daytime, keeping 5 m (16.4 feet) or more away from the subject.
- The ISO sensitivity is fixed to [AUTO].

**[SCENE MODE] menu (Refer to P56 for information about how to select the menu.)**

 **Food mode**

Select this mode when you want to take pictures of food without being affected by the ambient light, such as at restaurants. This mode allows you to take pictures of food in a natural hue.

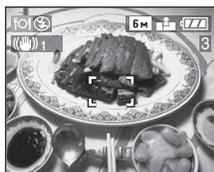

- The focus range becomes the same as that in the macro mode. [5 cm (0.16 feet) (Wide)/30 cm (0.98 feet) (Tele) to ∞]
- The ISO sensitivity is fixed to [AUTO].

 **Scenery mode**

This mode allows you to take a picture of a wide landscape. The camera focuses on a distant subject preferentially.



- The focus range is 5 m (16.4 feet) to ∞.
- The flash setting is fixed to Forced OFF [].
- The ISO sensitivity is fixed to [AUTO].
- The setting on the AF assist lamp is disabled.

**[SCENE MODE] menu (Refer to P56 for information about how to select the menu.)**

** Night portrait mode**

This mode allows you to take pictures against a night landscape. The subject can be recorded with brightness in real life by using the flash and slowing down the shutter speed.



**■ Technique for Night portrait mode**

- **Use the flash.**
- Since the shutter speed becomes slow, we recommend using a tripod and the self-timer (P41) for taking pictures.
- Keep the subject still for about 1 second when taking a picture.
- We recommend taking pictures by rotating the zoom lever to Wide (1×) and being at a distance about 1.5 m (4.92 feet) from the subject.



- The focus range is 1.2 m (3.94 feet) to 5 m (16.4 feet). (Refer to P39 for the flash control range.)
- The shutter may be kept closed (max. about 1 sec.) after taking a picture because of signal conditioning, but it is not a malfunction.
- When you take pictures in dark places, noise may become visible.
- The flash is always activated when the camera is set to Slow sync./Red-eye reduction [ ].
- The ISO sensitivity is fixed to [AUTO].

** Night scenery mode**

This mode allows you to take a picture of a nightscape. The landscape can be recorded vividly by slowing down the shutter speed.

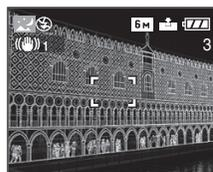

**■ Technique for Night scenery mode**

- Since the shutter speed becomes slow (max. about 8 sec.), use a tripod. We also recommend using the self-timer (P41) for taking pictures.



- The focus range is 5 m (16.4 feet) to ∞.
- The shutter may be kept closed (max. about 8 sec.) after taking a picture because of signal conditioning, but it is not a malfunction.
- When you take pictures in dark places, noise may become visible.
- The flash setting is fixed to Forced OFF [].
- The ISO sensitivity is fixed to [ISO80].
- The setting on the AF assist lamp is disabled.
- You cannot set the slow shutter.

**[SCENE MODE] menu (Refer to P56 for information about how to select the menu.)**

 **Baby mode**

Select this mode when you want to take pictures of baby. Exposure and hue are adjusted to achieve a healthy complexion on the baby. When the flash is used, the light is weaker than usual.

- When playing back pictures, baby's age can be displayed.
- The age can also be printed on each picture by using the software **[LUMIX Simple Viewer]** in the CD-ROM (supplied). (For details of printing, refer to the separate operating instructions for PC connection.)

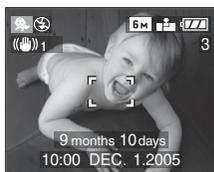

**Age display setting**

- If you want to display the age, set birthday in advance, select [WITH AGE] and press **▶**.
- If you do not want to display the age, select [WITHOUT AGE] and press **▶**.

**Birthday setting**

- 1 Select [BIRTHDAY SET.] and press **▶**.
- 2 When a message [PLEASE SET THE BIRTHDAY OF THE BABY] appears, select items (year, month and day) using **◀/▶**, and set using **▲/▼**.
- 3 Press the [MENU] button to finish the setting.

- If you select [WITH AGE] without setting birthday in advance, a message is displayed. Press the [MENU] button, and set birthday following the above steps 2 and 3.



- The focus range becomes the same as that in the macro mode. [5 cm (0.16 feet) (Wide)/30 cm (0.98 feet) (Tele) to ∞].
- The ISO sensitivity is fixed to [AUTO].
- After turning on the camera in [BABY] or switching to [BABY] from other modes, the age and current date and time are displayed for about 5 seconds at the bottom of the screen.
- The age display style differs depending on the language setting in the recording mode.
- The date of birth is displayed as [0 month 0 day].
- If the age is not properly displayed, check the clock and birthday settings.
- If the camera is set to [WITHOUT AGE], the age is not recorded even the time and birthday are set. This means that the age cannot be displayed even if you set the camera to [WITH AGE] after taking pictures.
- For resetting the birthday setting, use [RESET] in the [SETUP] menu. (P24)

[SCENE MODE] menu (Refer to P56 for information about how to select the menu.)

### **Soft skin mode**

In this mode, camera detects a skin-color area, such as face, to achieve a smooth appearance of the skin.



#### ■ Technique for Soft skin mode

To make this mode more effective:

- 1 Rotate the zoom lever to Tele as far as possible.
- 2 To maximize the effect, select a background as far as possible from the camera, and get closer to the subject.



- This mode is only suitable for outdoors in the daytime.
- The ISO sensitivity is fixed to [ISO80].
- If there is a color close to the skin color in the background, that part is also smoothened.
- This mode may not be effective in insufficient brightness.

### **Candle light mode**

Use this mode when you want to take photos with a candle light atmosphere.



#### ■ Technique for Candle light mode

- By making the most of the candle light, you can take successful pictures without using the flash.
- We recommend using a tripod and the self-timer (P41) for taking pictures.



- The flash setting can be set to Slow sync./ Red-eye reduction [] or Forced ON/ Red-eye reduction [].
- The ISO sensitivity is fixed to [AUTO].

**[SCENE MODE] menu (Refer to P56 for information about how to select the menu.)**

### **Party mode**

Select this mode when you want to take pictures at wedding receptions, indoor parties, etc.

Both the people and the background can be recorded with brightness in real life by using the flash and slowing down the shutter speed.



#### ■ **Technique for Party mode**

- Since the shutter speed becomes slow, we recommend using a tripod and the self-timer (P41) for taking pictures.
- We recommend taking pictures by rotating the zoom lever to Wide (1×) and being at a distance about 1.5 m (4.92 feet) from the subject.



- The flash setting can be set to Slow sync./ Red-eye reduction [] or Forced ON/ Red-eye reduction [].
- The ISO sensitivity is fixed to [AUTO].

### **Fireworks mode**

This mode allows you to take beautiful pictures of fireworks exploding in the night sky. The shutter speed or the exposure is automatically adjusted for taking pictures of fireworks.

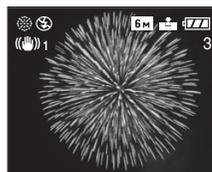

#### ■ **Technique for Fireworks mode**

- We recommend using a tripod.



- This mode is most effective when the distance to the subject is 10 m (32.8 feet) or longer.
- The flash setting is fixed to Forced OFF [].
- The ISO sensitivity is automatically adjusted to the optimal value.
- You cannot set the AF mode.
- The setting on the AF assist lamp is disabled.
- You cannot set the slow shutter.

**[SCENE MODE] menu (Refer to P56 for information about how to select the menu.)**

 **Snow mode**

This mode allows you to take a picture in locations such as skiing resorts and locations near snowy mountains. The exposure and the white balance are adjusted to make the white color of the snow stand out.



- The ISO sensitivity is fixed to [AUTO].

 **Starry sky mode**

This mode allows you to take beautiful pictures of a starry sky or a dark subject that you could not take in [NIGHT SCENERY]. It is possible to take clear pictures of stars in the night sky by making the shutter speed slower. Select a shutter speed of [15 SEC.], [30 SEC.] or [60 SEC.].

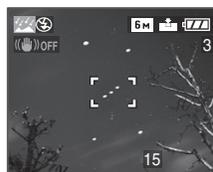

**Setting the shutter speed**

Press ▲/▼ to select the exposure time and press ►.

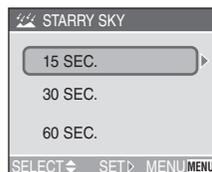

**[SCENE MODE] menu (Refer to P56 for information about how to select the menu.)**



- Press the shutter button until the countdown screen is displayed. Do not move the camera after this screen is displayed. When countdown finishes, [PLEASE WAIT...] is displayed for the same length of time as the set shutter speed for signal processing.
- If you press the [MENU] button while the picture is being taken, the picture will stop being taken.

■ **Technique for Starry sky mode**

- The shutter opens for 15, 30 or 60 seconds. Be sure to use a tripod. We also recommend taking pictures with the self-timer (P41).



- The optical image stabilizer function is fixed to [OFF].
- The flash setting is fixed to Forced OFF [🚫].
- The ISO sensitivity is fixed to [ISO80].
- You cannot compensate the exposure or set auto bracket, burst mode or [AUDIO REC.].
- Histograms are always displayed in orange. (P27)

 **Self portrait mode**

This mode allows you to take a picture of yourself.

■ **Technique for Self portrait mode**

When you are focused by pressing the shutter button halfway, the self-timer indicator lights up. Make sure to hold the camera still, and fully press the shutter button.

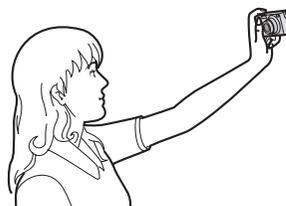

- The camera is not focused when the self-timer indicator is blinking. Make sure to press the shutter button halfway again to focus.
- The recorded picture automatically appears on the LCD monitor for reviewing. Refer to P36 for operations on the review function.
- When the picture is blurry due to slow shutter speed, we recommend using the 2 second self-timer. (P41)



- The available focus range is about 30 cm (0.98 feet) to 70 cm (2.30 feet).
- You can take a picture of yourself with audio (P72). In this time, the self-timer indicator lights up while recording the audio. (P41)
- When you select [SELF PORTRAIT], the zoom magnification is automatically moved to Wide (1×).
- The self-timer can be set to off or 2 seconds (P41). When you set to 2 seconds, it is kept until the camera is turned off or you switch the mode dial.
- The stabilizer function mode is fixed to [MODE2]. (P44)
- The ISO sensitivity is fixed to [AUTO].
- The AF mode is fixed to 5-area-focusing. (P73)
- The setting on the AF assist lamp is disabled.

## Using the [REC] mode menu



Setting the hue, picture quality adjustment, etc. allows you to create wide variations on taking pictures.

- Set the mode dial to the desired recording mode.

Menu items

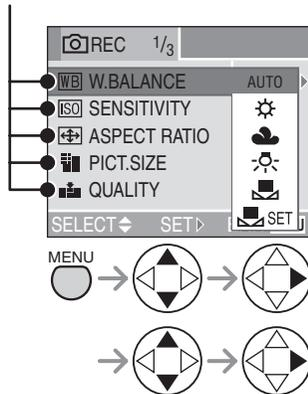

- When rotating the zoom lever toward T or W, the page of the menu screen can be forwarded or reversed.
- Close the menu by pressing the shutter button halfway or the [MENU] button after finishing the setting.

**WB** : [W.BALANCE] (P67)

**ISO** : [SENSITIVITY] (P69)

**ASPECT RATIO** : [ASPECT RATIO] (P69)

**PICT.SIZE** : [PICT.SIZE] (P70)

**QUALITY** : [QUALITY] (P72)

**AUDIO REC.** : [AUDIO REC.] (P72)

**AF** : [AF MODE] (P73)

**AF\*** : [AF ASSIST LAMP] (P74)

**SLOW** : [SLOW SHUTTER] (P75)

**D.ZOOM** : [D.ZOOM] (P75)

**COL.EFFECT** : [COL.EFFECT] (P76)

**PICT.ADJ.** : [PICT.ADJ.] (P76)

[REC] mode menu (Refer to P66 for the setting method.)

**WB** White Balance [W.BALANCE]



This function allows you to reproduce a white color closer to the tone in real life on the pictures recorded under sunlight, halogen lighting, etc. in which the white color may appear reddish or bluish.

<b>AUTO</b>	for auto setting (auto white balance)
<b>(Daylight)</b>	for recording outdoors on a bright day
<b>(Cloudy)</b>	for recording outdoors on a cloudy day
<b>(Halogen)</b>	for recording under halogen lighting
<b>(White set)</b>	for using the preset white balance
<b>(White set)</b>	for setting the white balance again (P68)

- When setting the white balance to the mode except [AUTO], you can finely adjust the white balance.

■ **Auto White Balance**

Use of auto white balance adjustment in inappropriate lighting conditions may result in reddish or bluish pictures. Where the subject is surrounded by many light sources, auto white balance adjustment may not operate properly.

In this case, set the white balance to a mode except [AUTO].

- 1 The range that is controlled by the auto white balance adjustment mode of the camera
- 2 Blue sky
- 3 Cloudy sky (Rain)
- 4 TV screen
- 5 Sunlight
- 6 White fluorescent light
- 7 Incandescent light bulb
- 8 Sunrise and sunset
- 9 Candlelight

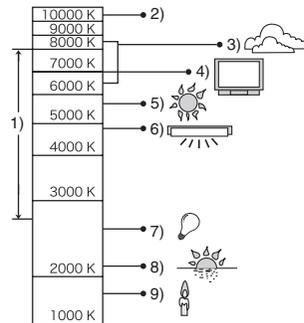

K=Kelvin Color Temperature

■ **Setting the White Balance manually**  
(White set )

Use this mode when you want to set the white balance manually.

- 1 Select [SET] (White Set) and then press **▶**.
- 2 Aim the camera at a sheet of white paper or a similar white object so that the frame in the center is filled by the white object and then press **▶**.



■ **Finely Adjusting the White Balance**  
(White Balance Fine Adjustment )

When you cannot acquire the desired hue by setting the white balance, you can adjust the white balance finely.

- 1 Set the white balance to [] / [] / [] / []. (P67)
- 2 Press **▲** [] several times until [ WB ADJUST.] appears.



- 3 Finely adjust the white balance.
  - **▶ [BLUE]:** Press when the hue is reddish.
  - **◀ [RED]:** Press when the hue is bluish.



**About the white balance**

- In simple mode [], the white balance is fixed to [AUTO].
- When taking a picture with the flash, the white balance will be automatically adjusted [except for [] (Daylight)], but the white balance may not be properly adjusted if the flash level is insufficient.

**About the white balance fine adjustment**

- The white balance icon on the screen turns red or blue.
- You can set the value independently for each of the modes in white balance.
- The setting on the fine adjustment of the white balance is reflected to the picture when taking a picture with the flash.
- When you set the white balance using the White Set [SET], the adjustment level in [] (White Set) returns to "0".
- When the color effect is set to any of [COOL], [WARM], [B/W] or [SEPIA] (P76), you cannot finely adjust the white balance.

[REC] mode menu (Refer to P66 for the setting method.)

**ISO** ISO Sensitivity [SENSITIVITY]



ISO sensitivity represents the sensitivity to light in values. If you set the ISO sensitivity higher, the camera becomes more suitable for recording in dark places.

- When [AUTO] is selected, the ISO sensitivity automatically increases to a maximum of [ISO200] (or [ISO400] when the flash is activated) depending on the brightness.

<b>ISO sensitivity</b>	80 ←————→ 400	
<b>Use in bright places (e.g. outdoors)</b>	Suitable	Not suitable
<b>Use in dark places</b>	Not suitable	Suitable
<b>Shutter speed</b>	Slow	Fast
<b>Noise</b>	Less	Increased



- In simple mode [♥], motion picture mode [H] or scene mode, ISO sensitivity is fixed to [AUTO]. (In [NIGHT SCENERY] (P59), [SOFT SKIN] (P61) and [STARRY SKY] (P63) in scene mode, it is fixed to [ISO80].)
- To avoid picture noise, we recommend decreasing the ISO sensitivity or setting [PICT.ADJ.] to [NATURAL]. (P76)

**Aspect Ratio** [ASPECT RATIO]



The aspect ratio is the horizontal to vertical ratio of a picture.

You can select from three aspect ratios.

<b>4:3</b>	<p>Normal ratio.</p>
<b>3:2</b>	<p>The screen becomes slight oblong in shape. Pictures are taken using the 3:2 aspect ratio, the same as for 35 mm film.</p>
<b>16:9</b>	<p>The picture is horizontally long. This is suited for landscapes and other subjects where you prefer a wide view. This is also suited for playing back on wide-screen TVs and high-definition TVs.</p>



- The ends of the recorded pictures may be cut at printing. Check the picture in advance. (P109)

**[REC] mode menu (Refer to P66 for the setting method.)****Picture Size [PICT.SIZE]**

When you select a larger picture size [**6M**] (6M), you can print pictures more clearly. When you select a smaller picture size [**0.3M**] (0.3M EZ), you can record more pictures. In addition, it is convenient to attach the picture to an e-mail or post it on a website because the file size is small.

■ When the aspect ratio is [**4:3**].

<b>6M</b> (6M)	2816×2112 pixels
<b>3M</b> (3M EZ)	2048×1536 pixels
<b>2M</b> (2M EZ)	1600×1200 pixels
<b>1M</b> (1M EZ)	1280×960 pixels
<b>0.3M</b> (0.3M EZ)	640×480 pixels

■ When the aspect ratio is [**3:2**].

<b>5M</b> (5M)	2816×1880 pixels
<b>2.5M</b> (2.5M EZ)	2048×1360 pixels

■ When the aspect ratio is [**16:9**].

<b>4.5M</b> (4.5M)	2816×1584 pixels
<b>2M</b> (2M EZ)	1920×1080 pixels



- “EZ” is an abbreviation for [Extended Optical Zoom]. This is a function which further extends the optical zoom ratio. If you select a picture size with EZ displayed, the zoom ratio is extended to a maximum of 4.1× when the digital zoom is set to [OFF]. (P71)
- In the motion picture mode [**MF**], the picture size is fixed to 640×480 pixels (VGA) or 320×240 pixels (QVGA).
- Pictures may appear like a mosaic depending on the subject or the recording condition.
- The number of recordable pictures depends on the subject.
- The number of remaining pictures displayed on the screen may not correspond with recorded frames.
- Refer to P18 for the number of recordable pictures.

■ Using the extended optical zoom (EZ)

When the optical zoom (P37) is used, subjects can usually be magnified up to 3 times. However, if you select a picture size such as [3M] (3M EZ) which activates the extended optical zoom, the zoom ratio will be extended as shown below.

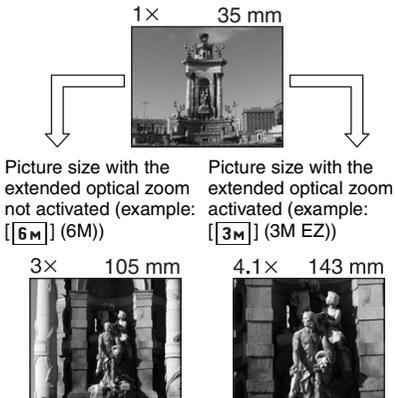

■ Extended optical zoom mechanism

- When you set the picture size to [3M] (3M EZ) (3 million pixels), the 6M (6 million pixels) CCD area is cropped to the center 3M (3 million pixels) area, allowing a picture with a higher zoom effect.

■ Picture size and maximum zoom magnification

(○: Available, —: Not available)

Aspect ratio	Picture size	Maximum zoom magnification	Extended optical zoom
4:3	6M (6M)	3x	—
3:2	5M (5M)		
16:9	4.5M (4.5M)		
4:3	3M (3M EZ)	4.1x	○
	2M (2M EZ)		
	1M (1M EZ)		
	0.3M (0.3M EZ)		
3:2	2.5M (2.5M EZ)		
16:9	2M (2M EZ)		



- You can further enhance the zoom magnification with the extended optical zoom without worrying about further picture distortion.
- If you set a picture size that activates the extended optical zoom, the extended optical zoom icon [EZ] is displayed on the LCD monitor when you use the zoom function.
- When the extended optical zoom is used, the zoom will stop moving for an instant near [W] (1x). This is not a malfunction.
- When you set [D.ZOOM] in the [REC] mode menu to [ON], the digital zoom can be used and subjects can be recorded at an even higher magnification. (P75)
- In motion picture mode [FH], the extended optical zoom does not work.

**[REC] mode menu (Refer to P66 for the setting method.)**

 **Quality [QUALITY]**



You can select 2 types of quality (compression level) according to the usage of the picture.

	<p><b>Fine (Low compression):</b> This type gives priority to picture quality. Picture quality will be high.</p>
	<p><b>Standard (High compression):</b> This type gives priority to the number of recordable pictures and records standard quality pictures.</p>



- 
- Pictures may appear like a mosaic depending on the subject or the recording condition.
  - The number of recordable pictures depends on the subject.
  - The number of remaining pictures displayed on the screen may not correspond with recorded frames.
  - Refer to P18 for the number of recordable pictures.

 **Audio Recording [AUDIO REC.]**



You can take a picture with audio.

- When you set [AUDIO REC.] to [ON], [] appears on the screen.
- When you start recording by focusing on the subject and pressing the shutter button, the audio recording will be automatically stopped in about 5 seconds. There is no need to keep pressing the shutter button.
- Audio is recorded from the built-in microphone of the camera.
- If you press the [MENU] button during the audio recording, the audio recording will be canceled. The audio cannot be recorded.
- You cannot take pictures with audio in auto bracket, burst mode or [STARRY SKY] (P63) in scene mode.
- When audio is recorded with each picture, the total number of pictures that can be stored on each card will slightly decrease.

[REC] mode menu (Refer to P66 for the setting method.)

**[AF] AF Mode [AF MODE]**



**[5-area-focusing]:**

The camera focuses on any of 5 focus areas. You can record a picture in free composition without limiting the position of the subject.



**[3-area-focusing (High speed)]:**

The camera focuses on any of the left, center and right of the screen.



**[1-area-focusing (High speed)]:**

The camera focuses on the subject in AF area on the center of the screen.



**[1-area-focusing]:**

The camera focuses on the subject in AF area on the center of the screen.



**[Spot-focusing]:**

The camera focuses on the limited and narrow area in the screen.



**High speed AF (H) mode**

- When you select 3-area-focusing (High speed) or 1-area-focusing (High speed), the auto focus is activated in high speed and you can focus on the subject more quickly.
- When you press the shutter button halfway, a picture may become still for a moment in the condition before being focused. However, it is not a malfunction. If you do not want to make pictures still during the auto focus, use the AF mode other than 3-area-focusing (High speed) mode and 1-area-focusing (High speed) mode.



- When using the digital zoom or when you take pictures in dark places, the AF area is displayed on the center of the screen with a size wider than usual.



- When multiple AF areas (max. 5 areas) light at the same time, the camera is focusing on all the AF areas. The focus position is not predetermined because it is set to the position that the camera automatically determines at the time of focusing. If you want to determine the focus position to take pictures, switch the AF mode to 1-area-focusing mode or Spot-focusing mode.
- The AF mode cannot be set in simple mode [♥], [FIREWORKS] (P62) or [SELF PORTRAIT] (P64) in scene mode.

**[REC] mode menu (Refer to P66 for the setting method.)****AF\* AF Assist Lamp**  
[AF ASSIST LAMP]

Illuminating the subject with the AF assist lamp allows the camera to focus on the subject in low light conditions.

When you press the shutter button halfway in dark places or other situations, an AF area wider than usual appears and the AF assist lamp  turns on.

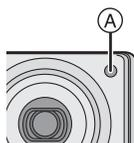

- Be sure of the following points when the AF assist lamp is in use.
  - Do not look into the AF assist lamp.
  - Do not cover the AF assist lamp with your fingers or other objects.
- In simple mode [, the setting on the [AF ASSIST LAMP] is fixed to [ON].
- You cannot use the AF assist lamp in [SCENERY] (P58), [NIGHT SCENERY] (P59), [FIREWORKS] (P62) and [SELF PORTRAIT] (P64) in scene mode.
- When you do not want to use the AF assist lamp (e.g. when you take a picture of a subject in a dark place), set the [AF ASSIST LAMP] to [OFF]. In this case, it becomes difficult to focus on the subject.
- When the AF assist lamp is turned on, an AF area with a size wider than usual normal AF area is indicated and the area is set only to a point on the center of the screen. (P73)

<b>ON</b>	The AF assist lamp turns on under low light conditions. In this time, the AF assist lamp icon [  , appears on the screen. The effective range of the AF assist lamp is 1.5 m (4.92 feet).
<b>OFF</b>	The AF assist lamp does not turn on.

**[REC] mode menu (Refer to P66 for the setting method.)****[SLOW] Slow Shutter [SLOW SHUTTER]**

The shutter speed can be automatically adjusted. However, if you want brighter pictures, you can manually select a slower shutter speed. This is especially effective if you want to take pictures where both the night landscape and the subject are bright, using [NIGHT PORTRAIT] (P59) in scene mode.

The slow shutter speed values you can select are: [1/8-], [1/4-], [1/2-] and [1-].

<b>Slow shutter setting</b>	1/8- ← → 1-
<b>Brightness</b>	Darker      Brighter
<b>Jitter</b>	Less      More

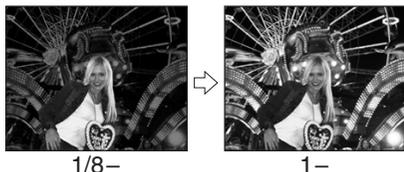
**■ Example**

- Usually, set to [1/8-] to take pictures. (When you select slow shutter speed values other than [1/8-], [SLOW] appears on the lower left of the LCD monitor.)
- When the shutter speed is made slower using [SLOW SHUTTER], jitter is likely to occur. We recommend using a tripod and the self-timer (P41) for taking pictures.
- You cannot set the slow shutter in [NIGHT SCENERY] (P59), [FIREWORKS] (P62) and [STARRY SKY] (P63) in scene mode.

**[D.ZOOM] Digital Zoom [D.ZOOM]**

When the digital zoom is set to [ON], the zoom ratio can be extended to a maximum of 12× using the 3× optical and 4× digital zoom functions. It can also be extended to a maximum of 16.4× using the 4.1× extended optical zoom and 4× digital zoom functions if the picture size activates the extended optical zoom (P71).

**■ Entering the digital zoom range**

When you rotate the zoom lever to the extreme Tele position, the on-screen zoom indication may momentarily pause. This is not a malfunction.

You can enter the digital zoom range by continuously rotating the zoom lever to Tele or releasing the zoom lever once and then rotate it to Tele again.

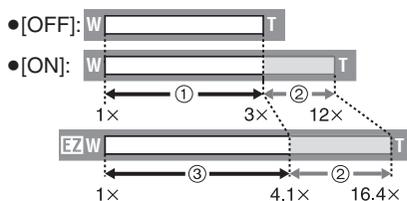

- ① Optical zoom
- ② Digital zoom
- ③ Extended optical zoom

**[REC] mode menu (Refer to P66 for the setting method.)**



- In the digital zoom, a larger picture has lower picture quality.
- In the digital zoom range, the stabilizer function may not be effective.
- When using the digital zoom, we recommend using a tripod and the self-timer (P41) for taking pictures.
- The indicated zoom magnification is an approximation.
- The AF area is displayed with a size wider than usual and set only to a point on the center of the screen in the digital zoom range. (P73)

 **Color Effect [COL.EFFECT]**



You can use 4 types of color effects depending on the atmosphere of the picture.

<b>COOL</b>	The picture becomes bluish.
<b>WARM</b>	The picture becomes reddish.
<b>B/W</b>	The picture becomes black and white.
<b>SEPIA</b>	The picture becomes sepia.

 **Picture Adjustment [PICT.ADJ.]**



Use this function according to the recording situation and the atmosphere of the picture.

<b>NATURAL</b>	The picture becomes softer.
<b>VIVID</b>	The picture becomes sharper.



- When you take pictures in dark places, noise may become visible. To avoid noise, we recommend setting [PICT.ADJ.] to [NATURAL].

## Playing Back Pictures with Audio/Motion Pictures



### ■ Pictures with audio

Select the picture with audio icon [  ] and play back the audio.

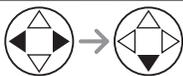

### ■ Motion pictures

Select the picture with the motion picture icon [  ]/[  ]/[  ]/[  ] and play back the motion pictures.

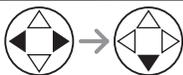

- The cursor displayed during playback corresponds to ▲/▼/◀/▶. 
- Motion picture playback stops and the normal playback is restored by pressing ▼.

### ■ Fast forwarding/Fast rewinding

During motion picture playback, keep pressing ◀/▶.

▶: Fast forward

◀: Fast rewind

- When releasing the button, it turns to normal motion picture playback.

### ■ To pause

Press ▲ during motion picture playback.

- Press ▲ again to cancel pause.



- Sound can be heard through the speaker. Refer to [VOLUME] (P23) for information about how to adjust the volume on the [SETUP] menu.

- Pictures with audio or motion pictures cannot be resized (P87) or trimmed (P88).
- You cannot use the zoom function while playing back or pausing motion pictures.
- The file format that can be played back with the camera is QuickTime Motion JPEG.
- Some QuickTime Motion JPEG files recorded by a PC or other equipment may not be played back with the camera.
- When playing back motion pictures that have been recorded with other equipment, the quality of pictures may be deteriorated or it may not be possible to play them back.
- When using a high capacity card, it is possible that fast rewinding may be slower than usual.

## Using the [PLAY] mode menu



You can use various functions in playback mode such as a rotating function or protections for recorded pictures.

Menu items

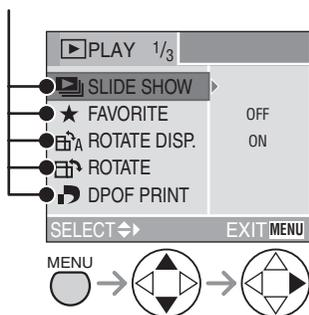

- When rotating the zoom lever toward T or W, the page of the menu screen can be forwarded or reversed.
- After selecting a menu item with the operation described above, make settings for each menu.

: [SLIDE SHOW] (P79)

: [FAVORITE] (P80)

: [ROTATE DISP.] (P81)

: [ROTATE] (P82)

: [DPOF PRINT] (P83)

: [PROTECT] (P85)

: [AUDIO DUB.] (P86)

: [RESIZE] (P87)

: [TRIMMING] (P88)

: [CLEAN UP] (P90)

: [FORMAT] (P91)

**[PLAY] mode menu (Refer to P78 for how to select the menu.)**

**Playing Back with Slide Show [SLIDE SHOW]**

**1 Select [ALL] or [★].**

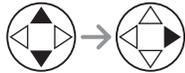

ALL	Displays all pictures.
★	Displays only those pictures that have been set as favorites (P80).

- [★] appears when [FAVORITE] is set to [ON]. When it is set to [OFF], perform step 2.
- However, if none of the pictures have [★] displayed, you cannot select [★] even if [FAVORITE] is set to [ON].

**2 Set the items of the Slide Show.**

(Screen when [ALL] is selected)

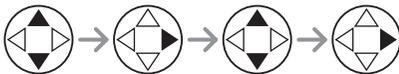
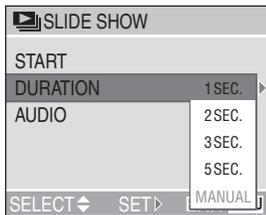

DURATION	Can be set at [1SEC.], [2SEC.], [3SEC.], [5SEC.] or [MANUAL] (manual playback).
AUDIO	By setting it to [ON], the audio of the pictures with audio can be played back during Slide Show.

- You can select [MANUAL] only when [★] has been selected in step 1.

**3 Select [START].**

(Screen when [ALL] is selected)

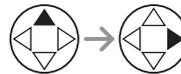
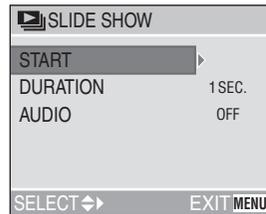

- When [MANUAL] is selected, press ◀▶ and confirm the previous and following pictures.

**4 By pressing the [MENU] button, the Slide Show stops.**



- Motion pictures cannot be played back in the Slide Show.
- When you set [AUDIO] to [ON] and then a picture with audio is played back, the next picture is displayed after playing back audio.

**[PLAY] mode menu (Refer to P78 for how to select the menu.)**

**★ Setting Favorites [FAVORITE]**

You can add a mark [★] (favorites icon) to your favorites pictures. After you set pictures as favorites, you can then delete the pictures not set as favorites ([ALL DELETE EXCEPT ★]) (P51) and play back the pictures set as favorites only as a Slide Show (P79). Before going to a photo studio for digital printing, using [ALL DELETE EXCEPT ★] is convenient so only the pictures you want the photo studio to print remain on the card.

**1 Select [ON] to set it.**

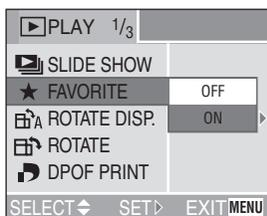

- You cannot set favorites if [FAVORITE] is set to [OFF]. Also [★] favorites icon will not appear when [FAVORITE] is set to [OFF] even if [FAVORITE] was previously set to [ON].

**2 Select the picture and set it.**



- Repeat the above procedure.
- If ▲ is pressed while the [★] favorites icon (A) is displayed, [★] is cleared, and the favorites setting is canceled.
- You can set up to 999 pictures as favorites.



- Using [LUMIX Simple Viewer] on the CD-ROM (supplied), favorites can be set, confirmed or deleted. (For details, please refer to the separate operating instructions for PC connection.)
- Pictures taken with different equipment may not be able to be set as favorites.

**[PLAY] mode menu (Refer to P78 for how to select the menu.)**

**Displaying pictures in a direction at the time of recording [ROTATE DISP.]**

This mode allows you to display pictures recorded by holding the camera vertically or pictures rotated in [ROTATE] function in the rotated direction.

**1 Select [ON] to set it.**

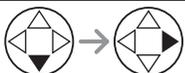
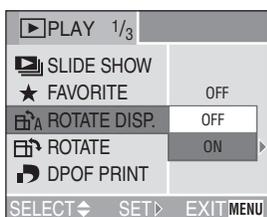

- When you select [OFF], the pictures are displayed without being rotated.
- Refer to P47 for how to play back pictures.



- When you take pictures by holding the camera vertically, read “Tips for taking good pictures” on P30 carefully.
- The direction detection function (P31) may not work properly on pictures recorded by aiming the camera up or down.
- When playing back rotated pictures in multi playback, pictures appear in original orientation.
- You can rotate and display pictures by using [ROTATE] function even if you do not take pictures by holding the camera vertically.
- When you connect the camera to a TV and play back a picture vertically, it may be blurry. [When using the AV cable (supplied)]

[PLAY] mode menu (Refer to P78 for how to select the menu.)

 **Rotating the Picture [ROTATE]**

You can rotate the recorded pictures in steps of 90° and display them.

■ **Example**

**When rotating clockwise (➡)**

Original picture

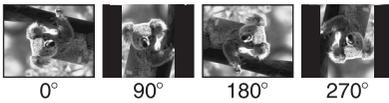

**1 Select the picture to be rotated and set it.**

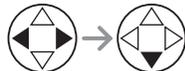
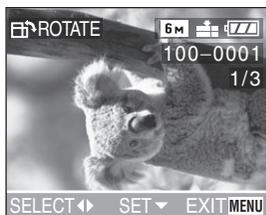

- Pictures recorded in motion picture mode [MOVIE] and protected pictures cannot be rotated.

**2 Select the direction to rotate the picture.**

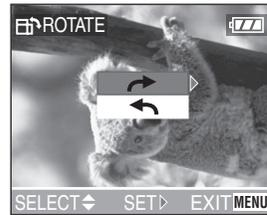

	The picture rotates clockwise in steps of 90°.
	The picture rotates counter-clockwise in steps of 90°.



- When you play back pictures on a PC, you cannot play back pictures keeping the rotated direction without an OS or software compatible with Exif.
- Exif is the file format for still pictures, to which recording information and other can be added, established by JEITA [Japan Electronics and Information Technology Industries Association].
- When [ROTATE DISP.] is set to [OFF], [ROTATE] function is disabled.
- When pictures are recorded by holding the camera vertically, the pictures are played back vertically (the pictures are rotated).
- It may not be possible to rotate pictures that have been recorded with other equipment.

**[PLAY] mode menu (Refer to P78 for how to select the menu.)**

**Setting the Picture to be Printed and the Number of Prints [DPOF PRINT]**

DPOF (Digital Print Order Format) is a system that allows the user to select which pictures are to be printed, how many copies of each picture will be printed or whether the recording date is to be printed on compatible photo printers or commercial photo printing services. For details, ask photo printing servicer. For more information please visit: [http://panasonic.jp/dc/dpof\\_110/white\\_e.htm](http://panasonic.jp/dc/dpof_110/white_e.htm)

**1 Select [SINGLE], [MULTI] or [CANCEL].**

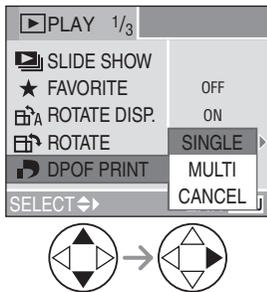

**Single setting**

Select the picture and set the number of prints.

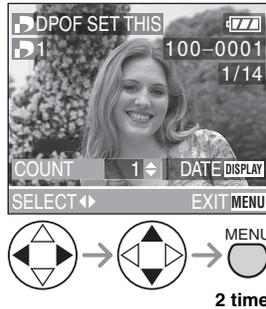

- The number of prints can be set from 0 to 999.
- The number of prints icon [1] appears.
- When the number of prints is set to "0", DPOF print setting is canceled.

**Multi setting**

Select the pictures and set the number of prints.

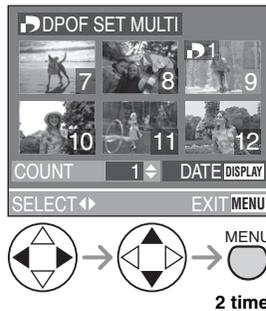

- Repeat the above procedure.
- The number of prints can be set from 0 to 999.
- The number of prints icon [1] appears.
- When the number of prints is set to "0", DPOF print setting is canceled.

■ To cancel all settings

Select [YES] to cancel all settings.

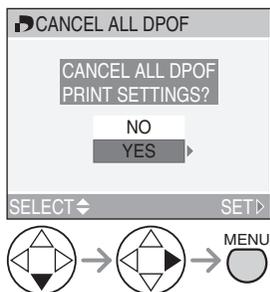

■ To print the date

You can set/cancel the printing with the recorded date by pressing the [DISPLAY] button after setting the number of prints.

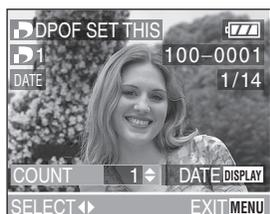

- The date print icon [DATE] appears.
- When using the software [LUMIX Simple Viewer] in the CD-ROM (supplied), you can print pictures with the date by setting the date print on the print settings. For details, refer to the separate operating instructions for PC connection.
- When you go to a photo studio for digital printing, be sure to order the printing of the date additionally if required.
- The date may not be printed depending on photo studios or printers even if you set the date print. For further information, ask the photo studio or refer to the operating instructions of the printer.



- DPOF print setting is a convenient function when you print pictures with printers supporting PictBridge. (P96)
- DPOF is an abbreviation of Digital Print Order Format. This feature allows you to write print information into the media and to use such information on the DPOF-compliant system.
- If the file is not based on the DCF standard, the DPOF print setting cannot be set. DCF is an abbreviation of [Design rule for Camera File system], stipulated by JEITA [Japan Electronics and Information Technology Industries Association].
- When setting the DPOF print on the camera, delete any previous DPOF print settings made by other equipment.

[PLAY] mode menu (Refer to P78 for how to select the menu.)

**Preventing Accidental Erasure of the Picture [PROTECT]**

You can set the protection for pictures you do not want to be deleted by accident.

**1 Select [SINGLE], [MULTI] or [CANCEL].**

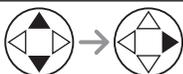
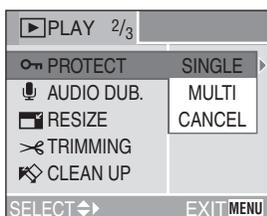

**■ Single setting**

Select the picture and set/cancel the protection.



2 times

SET	The protect icon [  ] appears.
CANCEL	The protect icon [  ] disappears.

**■ Multi setting/To cancel all settings**

Perform the same operation as in “Setting the Picture to be Printed and the Number of Prints [DPOF PRINT]”. (P83–84)



- If you want to delete protected pictures, cancel the protect setting first.
- While this feature protects the pictures from accidental erasure, formatting the card will permanently delete all data. (P91)
- The protect setting may not be effective in other equipment.
- Sliding the Card Write-Protect switch **(A)** on the SD Memory Card to [LOCK] prevents the picture from deletion even if the protection is not set.

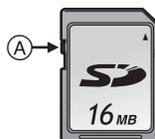

- The following functions cannot be used with protected pictures.
  - [ROTATE] (P82)
  - [AUDIO DUB.] (P86)

[PLAY] mode menu (Refer to P78 for how to select the menu.)

**Adding Audio to Recorded Pictures [AUDIO DUB.]**

You can record the audio after taking a picture (max. 10 seconds per picture).

**1 Select the picture and start audio recording.**



- When audio has already been recorded, the confirmation screen appears. Press ▼ to select [YES], and press ▶ to start audio recording. (The original audio is overwritten.)
- The audio dubbing cannot be used with the following pictures.
  - Motion pictures
  - Protected pictures
- The audio dubbing may not work properly on pictures recorded by other equipment.

**2 Stop audio recording.**



2 times

- The audio recording stops by pressing the ▼ button.
- Even if you do not press ▼, after about 10 seconds, the audio recording stops automatically.

[PLAY] mode menu (Refer to P78 for how to select the menu.)

 **Resizing the Pictures [RESIZE]**

This function is useful if you want to reduce the file size of the picture in cases when it needs to be attached to an e-mail or uploaded to a website.

**1 Select the picture and set it.**

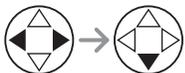
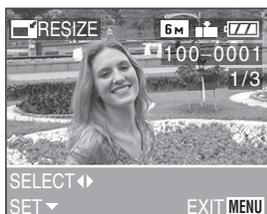

- The following pictures cannot be resized.
  - When the aspect ratio setting is [4:3].
    - Pictures recorded in [0.3M] (0.3M EZ)
  - When the aspect ratio setting is [3:2].
    - Pictures recorded in [2.5M] (2.5M EZ)
  - When the aspect ratio setting is [16:9].
    - Pictures recorded in [2M] (2M EZ)
    - Motion pictures
    - Pictures with audio
- It may not be possible to resize pictures recorded with other equipment.

**2 Select the size and set it.**



- Sizes smaller than the recorded picture are displayed.
- When the aspect ratio setting is [4:3].
  - [3M]/[2M]/[1M]/[0.3M]
- When the aspect ratio setting is [3:2].
  - [2.5M]
- When the aspect ratio setting is [16:9].
  - [2M]

**[PLAY] mode menu (Refer to P78 for how to select the menu.)**

**3 Select [YES] or [NO] and set it.**

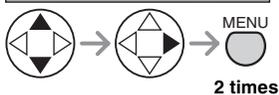

- When you select [YES], the picture is overwritten.  
When resized pictures are overwritten, they cannot be restored.
- When the original picture is protected, you cannot overwrite the resized picture.
- When you select [NO], a resized picture is newly created.

**> Trimming the Pictures [TRIMMING]**

Use this function when you trim needed parts of the recorded picture.

**1 Select the picture to trim and set it.**



- The following pictures cannot be trimmed.
  - Motion pictures
  - Pictures with audio
- It may not be possible to trim pictures recorded with other equipment.

**2 Enlarge or decrease the picture.**



**3 Shift the picture and press the shutter button to set.**

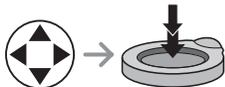
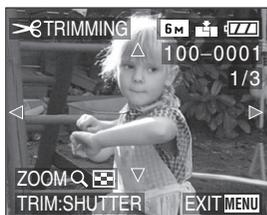

**4 Select [YES] or [NO] and set it.**

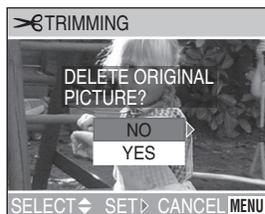

2 times

- When you select [YES], the picture is overwritten. When trimmed pictures are overwritten, they cannot be restored.
- When the original picture is protected, you cannot overwrite the trimmed picture.
- When you select [NO], a trimmed picture is newly created.



- The picture size of the trimmed pictures may become smaller than that of the original one depending on the cut size.
- The picture quality of the trimmed picture will be deteriorated.

**[PLAY] mode menu (Refer to P78 for how to select the menu.)**

**Clean-up [CLEAN UP]**

[CLEAN UP] recovers the data writing speed, which has been reduced, of the SD memory card.

In general, the data writing speed of the SD memory card reduces when recording and deletion are repeated. In this case, recording may stop in the middle while you are recording motion pictures. We recommend you to clean up the card using the camera before recording motion pictures.

**1 Select [YES] to start the clean-up.**

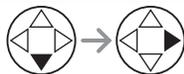
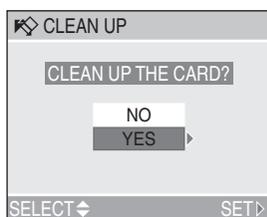

- [CLEAN UP] is a function to recover the speed of writing into a free space in the card. Therefore, pictures and data already recorded in the card will not be erased.
- When you start clean-up, it may take time to complete.
- Depending on the type of card, [CLEAN UP] may not be effective.
- [CLEAN UP] does not support MultiMediaCard.
- During clean-up do not turn the camera off.
- When you clean up the card, use a battery with sufficient battery power (P14) or AC adaptor (DMW-AC5; optional).
- When the SD Memory Card Write-Protect switch is slid to [LOCK], you cannot clean up the card.

[PLAY] mode menu (Refer to P78 for how to select the menu.)

### Initializing the Card [FORMAT]

1 Select [YES] to format.

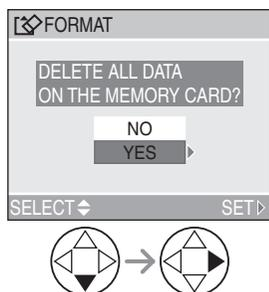

- Usually, it is not necessary to format the card. Format it when the message [MEMORY CARD ERROR] appears.
- If the card has been formatted by a PC or other equipment, format it on the camera again.
- **Once the card is formatted, all data including protected pictures are irretrievably erased. Please confirm that all data is transferred to your PC before proceeding with format function.**
- During formatting, do not turn the camera off.
- When you format the card, use a battery with sufficient battery power (P14) or AC adaptor (DMW-AC5; optional).
- When the SD Memory Card Write-Protect switch is slid to [LOCK], you cannot format the card.
- If the card cannot be formatted, consult your nearest servicer.

For USA assistance, please call: 1-800-272-7033  
or send e-mail to : [digitalstillcam@panasonic.com](mailto:digitalstillcam@panasonic.com)

For Canadian assistance, please call:  
1-800-561-5505 or visit us at [www.panasonic.ca](http://www.panasonic.ca)

## Playing Back Pictures on a TV Screen



### ■ Playing back pictures with AV cable (supplied)

- Turn the camera and the TV off.

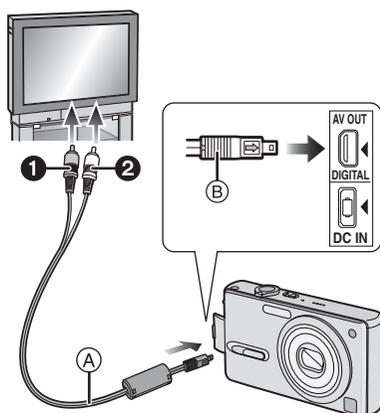

#### 1 Connect the AV cable (A) (supplied) to the [AV OUT] socket of the camera.

- Connect the AV cable with the [▶] mark facing the [◀] mark on the [AV OUT] socket.
- Hold the AV cable at (B) and insert straight in and take straight out.

#### 2 Connect the AV cable to the video input and the audio input sockets of the TV.

- ① Yellow: to the video input socket
- ② White: to the audio input socket

#### 3 Turn the TV on and select external input.

#### 4 Turn the camera on and then set the mode dial to playback mode [▶].

### ■ Viewing pictures in other countries

When setting [VIDEO OUT] on the [SETUP] menu, you can view pictures on the TV in other countries (regions) which use the NTSC or PAL system.

- Even if you set menu selection for [VIDEO OUT] to [PAL], the output signal is still NTSC in the recording mode.

### ■ Playback pictures on TV with SD Memory Card slot

Still pictures recorded to an SD Memory Card can be played back on TVs with an SD Memory Card slot.

(Pictures may not be displayed on a full screen, depending on the model of TV. MultiMediaCard may not be played back on TV with SD Memory Card slot.)

- Motion pictures cannot be played back. To play back motion pictures, connect the camera to a TV with the AV cable (supplied).



- Do not use any other AV cables except the supplied one.
- Read the TV operating instructions too.
- Audio playback is in monaural.
- When you connect the camera to a TV and play back a picture vertically, it may be blurry. (When using the AV cable)

## Before Connecting to the PC or the Printer

### [USB] : USB MODE]

Select the USB communication system before connecting the camera to your PC or your printer with the USB connection cable (supplied).

Set the items on [USB MODE] in the [SETUP] menu. (P24)



- When [PC] is selected, the camera is connected via USB Mass Storage communication system.
- When [PictBridge (PTP)] is selected, the camera is connected via PTP (Picture Transfer Protocol) communication system.

#### 1 Select [USB MODE].

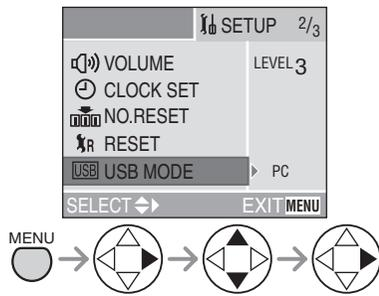

#### 2 Select [PC] or [PictBridge (PTP)].

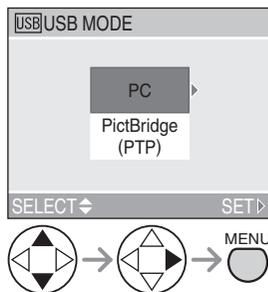

- If you connect the camera to a PC, select [PC]. (P94)
- If you connect the camera to a printer supporting PictBridge, select [PictBridge (PTP)]. (P96)

## Connecting to a PC

You can load pictures recorded with the camera to a PC by connecting the camera and PC.

The software [LUMIX Simple Viewer] (for Windows®) in the CD-ROM (supplied) allows you to load pictures recorded with the camera to a PC, print, or send them by e-mail easily.

**If you use Windows 98/98SE, install the USB driver and then connect it to the computer.**

For details of [LUMIX Simple Viewer] and installation, refer to the separate operating instructions for PC connection.

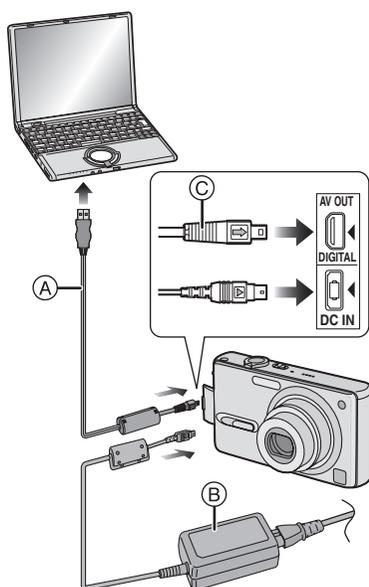

Ⓐ: USB connection cable (supplied)

Ⓑ: AC adaptor (DMW-AC5; optional)

- Turn off the camera before inserting or removing the cable for the AC adaptor (DMW-AC5; optional).

### 1 Turn the camera on and then set [USB MODE] on the [SETUP] menu to [PC]. (P93)

- If you set [USB MODE] to [PictBridge (PTP)] and then connect the camera to the PC, messages may appear on the screen of the PC.

Select [Cancel] to close the indications and disconnect the camera from the PC. Connect the camera after you set [USB MODE] again.

### 2 Connect the camera to a PC via the USB connection cable Ⓐ (supplied).

- Connect the USB connection cable with the [=>] mark facing the [◀] mark on the [DIGITAL] socket.
- Hold the USB connection cable at Ⓒ and insert straight in and take straight out. (Forcibly inserting at a slant or upside down can deform the pins, and this can damage the camera or other connected equipment.)



Ⓓ: This message appears during data transfer.

#### [Windows]

The drive appears on the [My Computer] folder.

- If it is the first time you are connecting the camera to a PC, the required driver is installed automatically so that the camera can be recognized by the Windows Plug and Play, then it appears on the [My Computer] folder.

#### [Macintosh]

The drive is displayed on the screen as [NO\_NAME] or [Untitled].

**Folder Composition**

The folder structure of the card or MultiMediaCard is displayed as the illustration below.

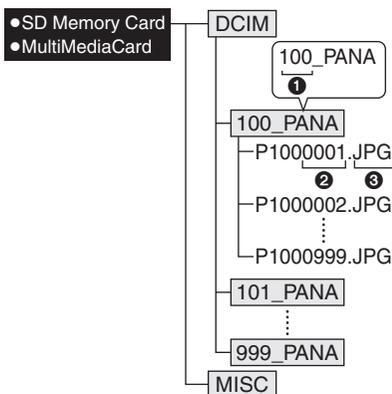

- ① Folder number
- ② File number
- ③ JPG: pictures  
MOV: motion pictures

Files will be saved in each folder as follows.

DCIM	Folders from [100_PANA] to [999_PANA]
100_PANA	Pictures/motion pictures
MISC	Files on which the DPOF print settings are recorded

- Picture data of up to 999 pictures recorded by the camera can be included in 1 folder. If the number of picture data exceeds 999, another folder will be created.
- When you reset the file number or the folder number, select [NO.RESET] in the [SETUP] menu. (P23)



- If the remaining battery power is exhausted during communication, the recorded data may be damaged. When you connect the camera to the PC, use a battery with sufficient battery power (P14) or the AC adaptor (DMW-AC5; optional).
- If the remaining battery power becomes low during communication, the battery indication turns red and blinks (P14) and the alarm beeps. In this case, stop the communication at once.
- While [ACCESS] is being displayed, do not disconnect the USB connection cable.
- **When the OS of your PC is Windows 2000 and you connect the camera to the PC with the USB connection cable, do not replace the card with the camera connected to the PC. The information in the card may be damaged. Make sure to disconnect the USB connection cable beforehand when you replace the card. For details, refer to the separate operating instructions for PC connection.**
- Do not use any other USB connection cables except the supplied one.
- Also refer to the operating instructions of the PC.

**PictBridge (PTP) setting**

Even if you set the [USB MODE] to [PictBridge (PTP)], you can connect to the PC only when the OS is Windows XP Home Edition, Windows XP Professional or Mac OS X.

- You can only load pictures from the camera and cannot write them on the card or delete them.
- When there are 1000 or more pictures on a card, the pictures may not be imported.

## Connecting to a PictBridge-compliant Printer

By connecting the camera directly to a printer supporting PictBridge via the USB connection cable (supplied), you can select the pictures to be printed or start printing on the LCD monitor.

Set the print settings such as print quality on the printer beforehand. (Read the printer operating instructions.)

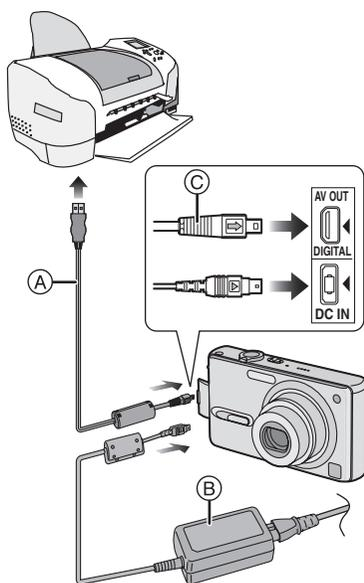

Ⓐ: USB connection cable (supplied)

Ⓑ: AC adaptor (DMW-AC5; optional)

- Turn off the camera before inserting or removing the cable for the AC adaptor (DMW-AC5; optional).

**1 Turn the camera on and then set [USB MODE] on the [SETUP] menu to [PictBridge (PTP)]. (P93)**

**2 Turn on the printer.**

**3 Connect the camera to a printer via the USB connection cable Ⓐ (supplied).**

- Connect the USB connection cable with the [➡] mark facing the [◀] mark on the [DIGITAL] socket.
- Hold the USB connection cable at Ⓒ and insert straight in and take straight out.

When the DPOF Print is not set.	Select [SINGLE PICTURE]. (P97)
When the DPOF Print is set. (P83)	Select [DPOF PICTURE]. (P98)



- It may take time to print some pictures. Therefore, use a battery with sufficient battery power (P14) or the AC adaptor (DMW-AC5; optional) when you connect to a printer.
- If the remaining battery power becomes low during communication, the battery indication turns red and blinks (P14) and the alarm beeps. In this case, stop the communication at once.
- Disconnect the USB connection cable after printing.
- Do not use any other USB connection cables except the supplied one.
- For printing the age in [BABY] (P60) in scene mode, print from a PC using the software [LUMIX Simple Viewer] in the CD-ROM (supplied). For details, refer to the separate operating instructions for PC connection.
- To find out more PictBridge compliant printers, please contact your local dealer.

■ Single picture

**1 Select a picture to be printed.**

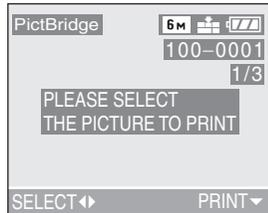

- The message disappears in about 2 seconds.

**2 Set the print settings.**

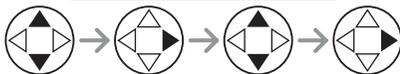
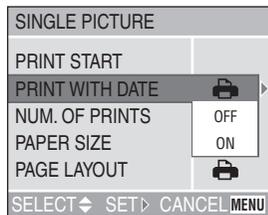

- The items which are not supported by the printer are displayed in gray and cannot be selected.
- When you want to print pictures in a paper size or a layout which is not supported by the camera, set [PAPER SIZE] or [PAGE LAYOUT] to [ ] and then set the paper size or the layout on the printer. (For details, refer to the operating instructions of the printer.)

• [PRINT WITH DATE]

	Settings on the printer are prioritized.
OFF	Date is not printed.
ON	Date is printed.

- If the printer does not support date printing, the date cannot be printed on the picture.

• [NUM. OF PRINTS]

Set the number of prints.

• [PAPER SIZE]

(Possible paper sizes on the camera)  
The items are listed on 1/2 and 2/2. Press ▼ to select the desired item.

1/2	
	Settings on the printer are prioritized.
L/3.5"×5"	89 mm×127 mm
2L/5"×7"	127 mm×178 mm
POSTCARD	100 mm×148 mm
A4	210 mm×297 mm
2/2*	
CARD SIZE	54 mm×85.6 mm
10×15cm	100 mm×150 mm
4"×6"	101.6 mm×152.4 mm
8"×10"	203.2 mm×254 mm
LETTER	216 mm×279.4 mm

\*These items cannot be displayed when the printer does not support the paper sizes.

• **[PAGE LAYOUT]**

(Possible layouts on the camera)

	Settings on the printer are prioritized.
	1 page with no frame print
	1 page with frame print
	2 pages print
	4 pages print

**3 Select [PRINT START] and then print out the picture.**

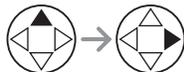
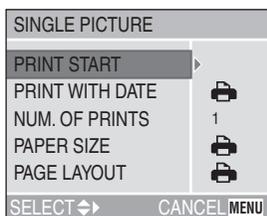

- Press the [MENU] button to cancel printing.

■ **DPOF picture**

- Set the DPOF print with the camera in advance. (P83)

**1 Select [DPOF PICTURE].**

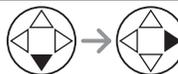
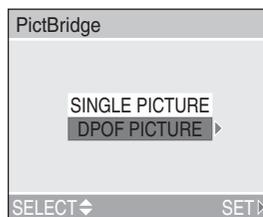

- When printing under the new settings, disconnect the USB connection cable and connect it to the printer again.
- You can change the DPOF print setting by pressing the [MENU] button. (P83)

**2 Select [PRINT START] and then print out the picture.**

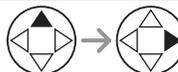
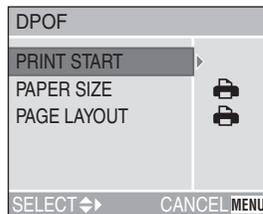

- Refer to P97 for print setting.
- Press the [MENU] button to cancel printing.

■ **Setting the date printing with the DPOF print in advance**

When the printer supports the date printing by DPOF setting, we recommend setting the date printing with the DPOF print in advance (P84). The recording date can be printed by selecting [DPOF PICTURE] to start printing.



- Do not disconnect the USB connection cable when the cable disconnection warning icon [ ] is indicated.
- When the [●] indication lights in orange during printing, the camera is receiving an error message from the printer. Make sure there is no malfunction on the printer after finishing printing.
- In DPOF print, if the total number of prints or the number of printed pictures is high, pictures may be printed several times. (The indication of the remaining number of prints is different from the setting, however, this is not a malfunction.)
- The setting on the printer may have priority over the setting on the camera in the date print. Also check the date print setting on the printer.
- If the printer does not support date printing, the date cannot be printed on the picture.

■ **Layout printing**

• **When printing a picture several times on 1 sheet of paper**

For example, if you want to print a picture 4 times on 1 sheet of paper, set [PAGE LAYOUT] to [ ] and then set the number of prints to 4 for the picture on [NUM. OF PRINTS].

• **When printing different pictures on 1 sheet of paper (only in DPOF printing)**

For example, if you want to print 4 different pictures on 1 sheet of paper, set [PAGE LAYOUT] to [ ] and then set the number of prints to 1 on [COUNT] in DPOF print setting (P83) for each of the 4 pictures.

## Screen Display

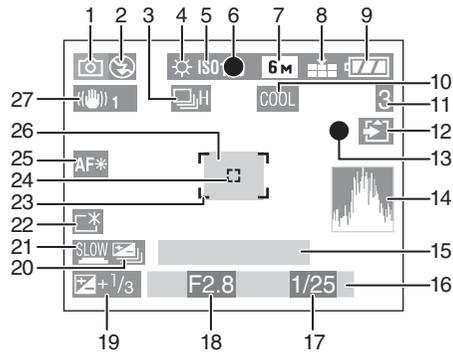

### ■ In recording

- |  |   |
|--|---|
| <p>1 Recording mode (P28)</p> <p>2 Flash mode (P38)</p> <p>3 Burst (P45)</p> <p>    : Audio recording (P54, 72)</p> <p>4 White balance (P67)</p> <p>5 ISO sensitivity (P69)</p> <p>6 Focus (P29)</p> <p>7 Picture size (P70)</p> <p>8 Quality (P72)</p> <p>    In Motion picture mode (P53)</p> <p>    : Jitter alert (P31)</p> <p>9 Battery indication (P14)</p> <p>10 Color effect (P76)</p> <p>11 Picture/Time remain</p> <p>    In Motion picture mode: e.g. 11S</p> <p>12 Card access indication (P17)</p> <p>13 Recording state</p> <p>14 Histogram (P27)</p> <p>15 Age (P60)</p> <p>    • This is displayed for about 5 seconds when turning on the camera in</p> | <p>    [BABY], setting the clock and birthday, and after switching from other modes to [BABY].</p> <p>16 Current date and time (P20)</p> <p>    • This is displayed for about 5 seconds when turning the camera on, setting the clock and after switching from the playback mode to the recording mode.</p> <p>    Zoom (P37)/Extended optical zoom (P71)/Digital zoom (P75)</p> <p>    </p> <p>17 Shutter speed (P29)</p> <p>18 Aperture value (P29)</p> <p>19 Exposure compensation (P42)</p> <p>20 Auto bracket (P43)</p> <p>21 Slow shutter (P75)</p> <p>22 Power LCD (P26)</p> <p>23 AF area (P29)</p> <p>24 Spot AF area (P73)</p> <p>25 AF assist lamp (P74)</p> <p>26 Self-timer (P41)</p> <p>    </p> <p>27 Optical image stabilizer (P44)</p> |
|--|---|

Others

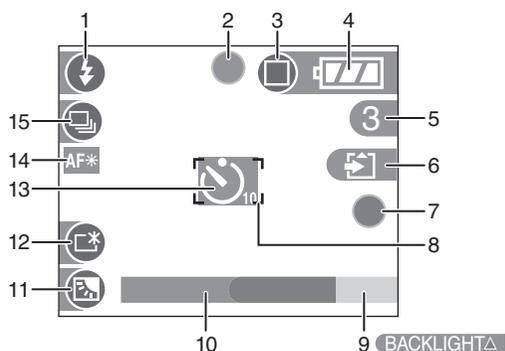

■ Recording in simple mode

- |  |  |
|--|--|
| <ul style="list-style-type: none"> <li>1 Flash mode (P38)</li> <li>2 Focus (P29)</li> <li>3 Picture mode (P33)</li> <li>    : Jitter alert (P31)</li> <li>4 Battery indication (P14)</li> <li>5 Pictures remaining</li> <li>6 Card Access indication (P17)</li> <li>7 Recording state</li> <li>8 AF area (P29)</li> <li>9 Operation for backlight compensation (P35)</li> </ul> | <ul style="list-style-type: none"> <li>10 Current date and time (P20) <ul style="list-style-type: none"> <li>• This is displayed for about 5 seconds when turning the camera on, setting the clock and after switching from the playback mode to the simple mode.</li> </ul> </li> <li>Zoom (P37)/Extended optical zoom (P71) <div style="border: 1px solid black; padding: 2px; display: inline-block; margin-top: 5px;">  Z W  T  1 X </div> </li> <li>11 Backlight compensation (P35)</li> <li>12 Power LCD (P26)</li> <li>13 Self-timer (P41)</li> <li>14 AF assist lamp (P74)</li> <li>15 Burst (P45)</li> </ul> |
|--|--|

Others

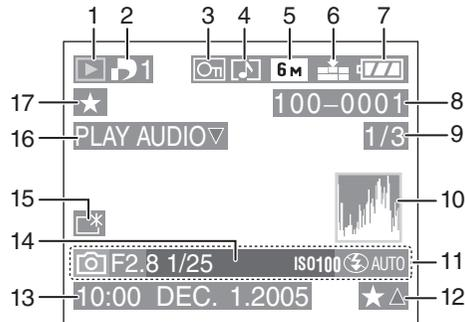

■ In playback

- |   |  |
|---|--|
| <p>1 Playback mode (P47)</p> <p>2 Number of DPOF prints (P83)</p> <p>3 Protected picture (P85)</p> <p>4 Picture with audio/Motion pictures (P77)</p> <p>5 Picture size (P70)</p> <p>6 Quality (P72)</p> <p>In Motion picture mode (P53)</p> <p> /  /  / </p> <p>Simple mode (P33)</p> <p> : ENLARGE</p> <p> : 4"×6"/10×15cm</p> <p> : E-MAIL</p> <p>7 Battery indication (P14)</p> <p>8 Folder/File number (P95)</p> <p>9 Page number/Total pictures</p> <p>10 Histogram (P27)</p> <ul style="list-style-type: none"> <li>• It will be displayed when the [DISPLAY] button is pressed.</li> </ul> | <p>11 Recording information (Recording mode/Aperture value/ Shutter speed/ISO sensitivity/Flash mode/White balance)</p> <ul style="list-style-type: none"> <li>• It will be displayed when the [DISPLAY] button is pressed.</li> </ul> <p>12 Favorites settings (P80)</p> <p>13 Recorded date and time</p> <p>14 Age (P60)</p> <p>15 Power LCD (P26)</p> <p>16 Audio playback (P77)</p> <p> : In Motion picture mode</p> <p>17 Favorites (P80)</p> |
|---|--|

## Cautions for Use

---

### ■ Optimal Use of the Camera

**When carrying the camera, take care not to drop or cause impact to it.**

- The lens or the outer case may be destroyed by the strong shock, and it causes a malfunction of the camera.

**Keep the camera away from magnetised equipment (such as a microwave oven, TV, video game equipment, etc.).**

- If you use the camera on or near a TV, pictures and sounds may be disrupted due to electromagnetic wave radiation.
- Do not use the camera near a cell phone because doing so may cause noise to adversely affect the pictures and sounds.
- Recorded data may be damaged, or pictures may be distorted by strong magnetic fields created by speakers or large motors.
- Electromagnetic wave radiation generated by a microprocessor may adversely affect the camera, causing the disturbance of pictures and sounds.
- If the camera is affected by magnetically charged equipment and does not function properly, turn the camera off and remove the battery or disconnect the AC adaptor (DMW-AC5; optional) and then insert the battery or connect the AC adaptor again. Thereafter, turn the camera on.

**Do not use the camera near radio transmitters or high-voltage lines.**

- If you record near radio transmitters or high-voltage lines, recorded pictures or sounds may be adversely affected.

**Make sure to use the supplied cords and cables. If you use optional accessories, use the cords and the cables supplied with them.**

**Do not extend the cords and the cables.**

**Do not spray insecticides or volatile chemicals onto the camera.**

- If the camera is sprayed with such chemicals, the camera body may be damaged and the surface finish may peel off.
- Do not keep rubber or plastic products in contact with the camera for a long period of time.

**Do not use benzine, thinner or alcohol for cleaning the camera.**

- Before cleaning the camera, remove the battery or disconnect the AC adaptor (DMW-AC5; optional) from the electrical outlet.
- The camera body may be deformed and the surface finish may peel off.
- Wipe the camera with a soft, dry cloth. To remove stubborn stains, wipe with a cloth that is soaked in a detergent diluted with water and afterward finish wiping with a dry cloth.
- If you use a chemical cloth, follow the instructions that come with the cloth.
- In case rain or other sources of water splash onto the camera, wet a soft cloth with tap water, wring it well, and use it to wipe the camera body carefully. Then wipe it again with a dry cloth.

*Others*

■ **Card**

**Do not leave the card in places where there is high temperature or direct sunlight, or where electromagnetic waves or static electricity are easily generated.**

**Do not bend or drop the card.**

- The card may be damaged or the recorded content may be damaged or erased.
- Store the card in the card case or the storage bag after use and when you store or carry the card.
- Do not allow dirt, dust or water to enter the terminals on the back of the card and do not touch the terminals with your fingers.

■ **Battery**

**The battery is a rechargeable lithium ion battery. Its ability to generate power is based upon the chemical reaction that takes place inside it. This reaction is susceptible to the surrounding temperature and humidity, and, if the temperature is too high or too low, the operating time of the battery will be shorter.**

**After use, be sure to remove the battery. Store the removed battery in the battery carrying case (supplied).**

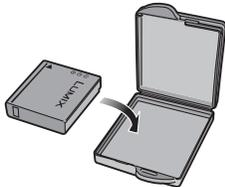

**If you drop the battery accidentally, check to see if the battery body and terminals are damaged.**

- Inserting a damaged battery in the camera will damage the camera.

**When you go out, bring charged spare batteries.**

- Be aware that the operating time of the battery will become shorter in low temperatures such as outdoors at a ski resort.
- When you travel, be sure to prepare the supplied charger to charge the battery on the spot.

**Dispose of an unusable battery.**

- The battery has a limited life.
- Do not throw the battery into fire because it may cause an explosion.
- An unusable battery should be discarded in accordance with battery recycling laws. For information you can call the RBRC hotline at 1-800-822-8837.

**Do not allow the battery terminals to come in contact with metal objects (such as necklaces, hairpins, etc.).**

- This can result in a short circuit or heat generation and, if you touch the battery in this condition, you may be badly burned.

■ **Charger**

- If you use the charger near a radio, radio reception may be disturbed. Keep the charger 1 m (3.28 feet) or more away from radio.
- When the charger is in use, it may generate whirring sounds. However, this is not a malfunction.
- After use, be sure to disconnect the charger from the electrical outlet. (If it is left connected, a minute amount of current is consumed.)
- Keep the terminals of the charger and battery clean.

## Message Display

---

Confirmation messages or error messages will be displayed on the screen in some cases.

Major messages are described below as examples.

**[THIS MEMORY CARD IS PROTECTED]**

Unlock [LOCK] of the Write-Protect switch on the SD Memory Card. (P17)

**[NO VALID PICTURE TO PLAY]**

Play back after recording or after inserting a card with a recorded picture.

**[THIS PICTURE IS PROTECTED]**

After canceling the protect setting, delete or overwrite the picture.

**[THIS PICTURE CANNOT BE DELETED]/[SOME PICTURES CANNOT BE DELETED]**

The pictures not based on the DCF standard cannot be deleted.

If you want to delete, format the card after saving necessary data on a PC or elsewhere.

**[CANNOT BE SET ON THIS PICTURE]/[CANNOT BE SET ON SOME PICTURES]**

If the pictures are not based on the DCF standard, the DPOF print cannot be set.

**[NO ADDITIONAL DELETE SELECTIONS CAN BE MADE]**

You have exceeded the number of pictures that can be set at once with [MULTI DELETE]. Once delete the selected pictures and then repeat deleting multiple pictures.

More than 999 favorites have been set.

**[MEMORY CARD ERROR  
FORMAT THIS CARD?]**

The format of the card cannot be recognized by the camera. Format the card again with the camera after saving necessary data on a PC or elsewhere.

**[PLEASE TURN CAMERA OFF AND THEN ON AGAIN]**

This message appears when the camera does not operate properly. Turn the camera off and on. If the message persists, contact the dealer or your nearest servicenter.

**[MEMORY CARD ERROR  
PLEASE CHECK THE CARD]**

Failed access to the card.

Insert the card again.

**[READ ERROR  
PLEASE CHECK THE CARD]**

Data reading error.

Be sure that the card is inserted securely and then play it back again.

**[WRITE ERROR  
PLEASE CHECK THE CARD]**

Data writing error.

Turn the camera off and remove the card. Then insert the card and turn the camera on again. Be sure that the camera is turned off before removing or inserting the card to avoid damage.

**[MOTION RECORDING WAS  
CANCELLED DUE TO THE LIMITATION  
OF THE WRITING SPEED OF THE  
CARD]**

- When you set the picture quality to [30fpsVGA], we recommend using a high speed SD Memory Card with "10 MB/s" or greater displayed on the package.
- Depending on the type of SD Memory Card and how many times it has been recorded onto or deleted, recording may stop in the middle. If something like this happens, clean-up may be effective. We recommend you clean up the card using the camera in advance. (P90)

**[A FOLDER CANNOT BE CREATED]**

A folder cannot be created because the card is full.

Format the card after deleting unnecessary data or saving necessary data on a PC or elsewhere.

## Troubleshooting

---

If you put the menu back to the settings at the time of purchase, the conditions may be improved.

**Carry out the [RESET] in the [SETUP] menu. (P24)**

---

### ■ Battery and the power source

#### 1: The camera cannot be operated even when it is turned on.

- Is the battery inserted correctly?
  - Check the direction of the battery. (P15)
- Is the battery sufficiently charged?
  - Use a battery that has been sufficiently charged.

#### 2: The LCD monitor is turned off even when the camera is turned on.

- Is the power save mode (P22) or economy mode (P23) activated?
  - Press the shutter button halfway to cancel these modes.
- Is the battery charge insufficient to operate the camera?
  - Use a battery that has been sufficiently charged.

#### 3: The camera is turned off immediately even after it is turned on.

- Is the battery charge insufficient to operate the camera?
    - Use a battery that has been sufficiently charged.
    - If you leave the camera with turning it on, the battery is exhausted. Turn the camera off frequently by using the power save mode (P22), the economy mode (P23), etc.
- 

### ■ Recording

#### 1: The picture cannot be recorded.

- Is the card inserted?
- Is the mode dial correctly set?
- Is there any memory capacity left on the card?
  - Before recording, delete some pictures.

#### 2: The subject is not focused properly.

- The focus range varies depending on the recording mode.
  - Rotate the mode dial to set to the proper mode for the distance to the subject.
- Is the subject out of the focus range? (P31)
- When you cannot focus on the subject even if you tried many times, turn the camera off once and turn it on again.

#### 3: The recorded picture is blurred.

- When taking a picture especially in dark places, the shutter speed becomes slow and the optical image stabilizer function may not work properly. In this case, we recommend holding the camera with both hands firmly to take pictures (P30). When the [SLOW SHUTTER] (P75) is set, we recommend using a tripod and the self-timer (P41) for taking pictures.

#### 4: The recorded picture is whitish. The lens is dirty.

- The picture can become whitish if there is dirt e.g. fingerprints on the lens. If the lens is dirty, turn on the camera, eject the lens barrel (P11) and gently wipe the lens surface with a soft dry cloth.

**5: Motion picture recording stops in the middle.**

- Are you using a MultiMediaCard?
  - This unit does not support MultiMediaCard.
- When you set the picture quality to [30fpsVGA], we recommend using a high speed SD Memory Card with “10 MB/s” or greater displayed on the package.
- Depending on the type of SD Memory Card and how many times it has been recorded onto or deleted, recording may stop in the middle. If something like this happens, clean-up may be effective. We recommend you clean up the card using the camera in advance. (P90)

**■ LCD monitor****1: The LCD monitor is turned off sometimes although the camera is turned on.**

- Have you set to the economy mode? (P23)
  - In the economy mode, the LCD monitor is turned off while the flash is charged.

**2: The brightness of the screen becomes dark or bright for a moment.**

- This phenomenon appears when pressing the shutter button halfway to set the aperture value and does not affect the recorded pictures.

**3: The screen is too bright or dark.**

- Adjust the brightness of the screen. (P22)
- Is the power LCD function activated? (P26)

**4: Some pixels are inactive or always lit on the LCD monitor.**

- These pixels do not affect the recorded pictures.  
This is not a malfunction.

**5: Noise appears on the LCD monitor.**

- In dark places, noise may appear to maintain the brightness of the LCD monitor.  
This does not affect the pictures you are recording.

**6: A vertical red line appears on the LCD monitor.**

- This is called smear. It is specific to CCD, not a malfunction. It appears when the subject has a bright part. It is recorded on motion pictures, but not recorded on still pictures.

**■ Flash****1: Flash is not activated.**

- Is the flash setting set to Forced OFF [?
  - Change the flash setting. (P38)
- The flash is not activated when in motion picture mode [], [SCENERY] (P58), [NIGHT SCENERY] (P59), [FIREWORKS] (P62) or [STARRY SKY] (P63) in scene mode is selected.

**2: The flash is activated 2 times.**

- When you select AUTO/Red-eye reduction [], the first flash is activated for red-eye prevention on the subject (red-eye phenomenon) before actually recording pictures. After the first flash, the flash is activated again for recording.

---

## ■ Playback

### 1: Pictures being played are rotated and displayed in an unexpected direction.

The camera has a function to automatically rotate and display pictures recorded by holding the camera vertically.

(If you take pictures aiming the camera up or down, the camera may recognize that it is held vertically.)

- When [ROTATE DISP.] (P81) is set to [OFF], you can display the pictures without being rotated.
- You can rotate pictures with [ROTATE] function. (P82)

### 2: The picture is not played back.

- Is the mode dial set to playback [▶]?
- Is the card inserted?
- Is there a picture in the card?

### 3: The picture played back looks rough. Noise appears on the picture.

- Is the ISO sensitivity is high or is the shutter speed slow?
  - Decrease the ISO sensitivity. (P69)
  - Set [PICT.ADJ.] to [NATURAL]. (P76)
  - Take pictures in bright places.

### 4: The folder number and the file number are displayed as [—] and the screen may turn black.

- Is the picture edited with a PC or recorded with the digital camera other than Panasonic?
 

This may also result if the battery is removed immediately after recording or by recording with the exhausted battery.

    - In order to delete the pictures mentioned above, format the data. (P91) (Once formatted, all the data including the other pictures cannot be restored. Confirm carefully to format.)
- 

## ■ TV, PC and printer

### 1: The picture does not appear on the television.

- Is the camera connected to the TV correctly?
- Set the TV input to external input mode.

### 2: The display areas on the TV screen and the camera's LCD monitor are different.

With some TV models, the area display is smaller so the top and bottom or left and right of the picture may appear cut off when the picture is displayed. This is not a malfunction.

### 3: When connecting to a PC, pictures cannot be transferred.

- Is the camera connected to the PC correctly?
- Is the camera recognized by the PC correctly?
- Set [USB MODE] to [PC]. (P93)

### 4: The card is not recognized by the PC.

- Disconnect the USB connection cable and then connect it again with the card inserted into the camera.

### 5: The pictures cannot be printed with the camera connected to printers.

- Is the printer supporting PictBridge?
  - You cannot print pictures with printers which do not support PictBridge. (P96)
- Set [USB MODE] to [PictBridge (PTP)]. (P93)

### 6: The ends of the pictures are cut at printing.

- When using the printer with a trimming feature or other feature which cuts out both edges of the pictures, cancel the feature for printing. The feature depends on the printer used. (Refer to the operating instructions of the printer for details.)
  - When you order photo studios to print pictures, ask the photo studio if the pictures can be printed with both ends.
-

---

**■ Others**
**1: Unreadable language was selected by mistake.**

- Press the [MENU] button and select [Q] icon on the [SETUP] menu to set the desired language.

**2: The setting for the auto review function is disabled.**

- Is the camera in auto bracket (P43), burst mode (P45), motion picture mode [H] (P53), [SELF PORTRAIT] (P64) in scene mode, or is [AUDIO REC.] set to [ON] (P72)?
  - In these cases, you cannot set the auto review function in the [SETUP] menu.

**3: When the shutter button is pressed halfway, a red lamp sometimes turns on.**

- In dark places, the AF assist lamp (P74) lights red to make it easier to focus on a subject.

**4: The AF assist lamp does not turn on.**

- Is [AF ASSIST LAMP] on the [REC] mode menu set to [ON]?
- Are you taking pictures in a dark place?
  - The AF assist lamp does not turn on in bright places.
- The AF assist lamp does not turn on when [SCENERY] (P58), [NIGHT SCENERY] (P59), [FIREWORKS] (P62), or [SELF PORTRAIT] (P64) in scene mode is selected.

**5: The camera is getting warmer.**

- The surface of the camera may get warmer during use. This does not cause a problem with the performance or quality of the camera.

**6: The lens clicks.**

- When brightness has changed due to the zoom or the movement of the camera or other, the lens may click and the picture on the screen may be drastically changed, however, the pictures are not affected. The sound is caused by automatic adjustment of the aperture. It is not a malfunction.

**7: The clock setting is reset.**

- If you do not use the camera for a long time, the clock setting may be reset. When the message [PLEASE SET THE CLOCK] appears, set the clock again.
- When you take a picture before setting the clock, [0:00 0. 0. 0] is recorded.

**8: Colors that were actually not around the subject appear on the picture.**

- On the camera, color shift may appear by the characteristic of the lens. This is not a malfunction.
-

## Specifications

<b>Digital Camera:</b>	Information for your safety
<b>Power Source:</b>	DC 5.1 V
<b>Power Consumption:</b>	1.8 W (When recording) 0.9 W (When playing back)
<b>Camera effective pixels:</b>	6,000,000 pixels
<b>Image sensor:</b>	1/2.5" CCD, total pixel number 6,370,000 pixels, Primary color filter
<b>Lens:</b>	Optical 3× zoom, f=5.8 mm to 17.4 mm (35 mm film camera equivalent: 35 mm to 105 mm)/F2.8 to F5.0
<b>Digital zoom:</b>	Max. 4×
<b>Focus:</b>	Normal/Macro, 5-area-focusing/3-area-focusing (High speed)/ 1-area-focusing (High speed)/1-area-focusing/Spot-focusing
<b>Focus range:</b>	Normal: 50 cm (1.64 feet) to ∞ Macro/Simple: 5 cm (0.16 feet) (Wide)/30 cm (0.98 feet) (Tele) to ∞
<b>Shutter system:</b>	Electronic shutter+ Mechanical shutter
<b>Burst recording</b>	
<b>Burst speed:</b>	3 frames/second (High speed), 2 frames/second (Low speed), Approx. 1.5 frames/second (Unlimited)
<b>Number of recordable pictures:</b>	Max. 8 frames (Standard), max. 6 frames (Fine), Depends on the remaining capacity of the card (Unlimited). (Performance in burst recording is only with SD Memory Card. MultiMediaCard performance will be less.)
<b>Motion picture recording:</b>	640×480 pixels/320×240 pixels (30 or 10 frames/second with audio. The maximum recording time depends on the capacity of the card.)
<b>ISO sensitivity:</b>	AUTO/80/100/200/400
<b>Shutter speed:</b>	8 to 1/2000th [STARRY SKY] mode: 15 seconds, 30 seconds, 60 seconds Motion picture mode: 1/30th to 1/2000th
<b>White balance:</b>	AUTO/Daylight/Cloudy/Halogen/White set
<b>Exposure (AE):</b>	Program AE Exposure compensation (1/3 EV Step, -2 EV to +2 EV)
<b>Metering mode:</b>	Multiple
<b>LCD monitor:</b>	2.5" low-temperature polycrystalline TFT LCD (Approx. 207,000 pixels) (field of view ratio about 100%)
<b>Flash:</b>	Flash range: (ISO AUTO) Approx. 30 cm (0.98 feet) to 4.0 m (13.1 feet) (Wide) AUTO, AUTO/Red-eye reduction, Forced ON (Forced ON/ Red-eye reduction), Slow sync./Red-eye reduction, Forced OFF
<b>Microphone:</b>	Monaural
<b>Speaker:</b>	Monaural
<b>Recording media:</b>	SD Memory Card/ MultiMediaCard (Still pictures only)

Others

**Picture size**

**Still picture:**

When the aspect ratio setting is [ 4:3 ]  
2816×2112 pixels, 2048×1536 pixels, 1600×1200 pixels,  
1280×960 pixels, 640×480 pixels

When the aspect ratio setting is [ 3:2 ]  
2816×1880 pixels, 2048×1360 pixels

When the aspect ratio setting is [ 16:9 ]  
2816×1584 pixels, 1920×1080 pixels  
640×480 pixels/320×240 pixels

**Motion pictures:**

**Quality:**

Fine/Standard

**Recording file format**

**Still Picture:**

JPEG (based on Design rule for Camera File system, based on Exif 2.2 standard)/DPOF corresponding

**Picture with audio:**

JPEG (based on Design rule for Camera File system, based on Exif 2.2 standard)+QuickTime (picture with audio)  
QuickTime Motion JPEG (motion pictures with audio)

**Motion pictures:**

**Interface**

**Digital:**

USB 2.0 (Full Speed)

**Analog video/audio:**

NTSC/PAL Composite (Switched by menu),  
Audio line output (monaural)

**Terminal**

**AV OUT/DIGITAL:**

Dedicated jack (8 pin)

**DC IN:**

Dedicated jack

**Dimensions:**

Approx. 94.1 mm (W)×50.5 mm (H)×24.2 mm (D) [3 11/16" (W)×1 15/16" (H)×15/16" (D)] (excluding the projection part)

**Mass:**

Approx. 127 g/4.48 oz  
(excluding Memory Card and battery)  
Approx. 155 g/5.47 oz (with Memory Card and battery)

**Operating Temperature:**

0 °C to 40 °C (32 °F to 104 °F)

**Operating Humidity:**

10% to 80%

**Battery Charger**

**(Panasonic DE-A11B):**

Information for your safety

<b>Input:</b>	110 V to 240 V ~ 50/60 Hz, 0.2 A
<b>Output:</b>	CHARGE 4.2 V = 0.8 A

**Equipment mobility:**

Movable

**Battery Pack (lithium-ion)**

**(Panasonic CGA-S005A):**

Information for your safety

<b>Voltage/capacity:</b>	3.7 V, 1150 mAh
--------------------------	-----------------

## Digital Camera Accessory System

Accessory#	Figure	Description
CGA-S005A		Battery Pack
DMW-AC5		AC Adaptor
RP-SDK02GU1A RP-SDK01GU1A RP-SDK512U1A RP-SD512BU1A RP-SDH256U1A RP-SD256BU1A RP-SD128BU1A RP-SD064BPPA RP-SD032BPPA		2 GB SD Memory Card 1 GB SD Memory Card 512 MB SD Memory Card 512 MB SD Memory Card 256 MB SD Memory Card 256 MB SD Memory Card 128 MB SD Memory Card 64 MB SD Memory Card 32 MB SD Memory Card
BN-SDCAPU/1B		SD USB Reader/Writer (compatible with MultiMediaCard)
BN-SDABPU/1B		SD PC Card Adaptor (compatible with MultiMediaCard)

- Please refer to P14, for details on the battery charging time and the number of recordable pictures.
- NOTE: Accessories and/or model numbers may vary by country. Please consult your local dealer.

Others

# Digital Camera Accessory Order Form

(For USA Customers)

Please photocopy this form when placing an order.

1. Digital Camera Model # \_\_\_\_\_

2. Items Ordered

Accessory #	Description	Price Each	Quantity	Total Price
Subtotal				
Your State & Local Sales Tax				
Shipping & Handling				6.95
Total Enclosed				

3. Method of payment (check one)

- Check of Money Order enclosed (NO C.O.D.SHIPMENTS)
- VISA                      Credit Card # \_\_\_\_\_
- MasterCard              Expiration Date \_\_\_\_\_
- Discover                    Customer Signature \_\_\_\_\_

Make Check or Money Order to: PANASONIC ACCESSORIES

(Please do not send cash)

4. Shipping information (UPS delivery requires complete street address)

Ship To:

Mr.

Mrs.

Ms.

First \_\_\_\_\_ Last \_\_\_\_\_

Phone#:

Day ( ) \_\_\_\_\_

Street Address \_\_\_\_\_

Night ( ) \_\_\_\_\_

City \_\_\_\_\_ State \_\_\_\_\_ Zip \_\_\_\_\_

TO OBTAIN ANY OF OUR DIGITAL CAMERA ACCESSORIES YOU CAN DO ANY OF THE FOLLOWING:

VISIT YOUR LOCAL PANASONIC DEALER

OR

CALL PANASONIC'S ACCESSORY ORDER LINE AT 1-800-332-5368

[6 AM-5 PM M-F, 6 AM-10:30 AM SAT, PACIFIC TIME]

OR

MAIL THIS ORDER TO: PANASONIC SERVICES COMPANY ACCESSORY ORDER OFFICE  
20421 84th Avenue South Kent, WA. 98032

In CANADA, please contact your local Dealer for more information on Accessories.

114

VQT0S57

Others

## Request for Service Notice (For USA Only)

---

Please photocopy this form when making a request for service notice.

In the unlikely event this product needs service.

### Request for Service Notice: (USA Only)

- Please include your **proof of purchase.**  
(Failure to do so will delay your repair.)
- To further speed your repair, please provide an explanation of what wrong with the unit and any symptom it is exhibiting.

---

---

---

---

Mail this completed form and your Proof of Purchase along with your unit to:  
Panasonic Services Company  
1705 N. Randall Road  
Elgin, IL. 60123-7847  
Attn: Digital Camera Repair

Others

## Limited Warranty (For USA Only)

---

PANASONIC CONSUMER  
ELECTRONICS COMPANY,  
DIVISION OF PANASONIC  
CORPORATION OF NORTH  
AMERICA

One Panasonic Way, Secaucus, New  
Jersey 07094

PANASONIC PUERTO RICO, INC.  
Ave. 65 de Infantería, Km. 9.5, San  
Gabriel Industrial Park, Carolina,  
Puerto Rico 00985

### Panasonic Digital Still Camera Limited Warranty

#### Limited Warranty Coverage

If your product does not work properly because of a defect in materials or workmanship, Panasonic Consumer Electronics Company or Panasonic Puerto Rico, Inc. (collectively referred to as "the warrantor") will, for the length of the period indicated on the chart below, which starts with the date of original purchase ("warranty period"), at its option either (a) repair your product with new or refurbished parts, or (b) replace it with a new or refurbished product. The decision to repair or replace will be made by the warrantor.

PRODUCT OR PART NAME	PARTS	LABOR
<b>DIGITAL STILL CAMERA</b> (EXCEPT ITEMS LISTED BELOW)	<b>1 (ONE) YEAR</b>	<b>90 (NINETY) DAYS</b>
<b>CCD</b>	<b>6 (SIX) MONTHS</b>	<b>90 (NINETY) DAYS</b>
<b>RECHARGEABLE BATTERY PACK</b> (IN EXCHANGE FOR DEFECTIVE BATTERY PACK)	<b>90 (NINETY) DAYS</b>	<b>NOT APPLICABLE</b>
<b>SD MEMORY CARD</b> (IN EXCHANGE FOR DEFECTIVE SD CARD)	<b>90 (NINETY) DAYS</b>	<b>NOT APPLICABLE</b>

During the "Labor" warranty period there will be no charge for labor. During the "Parts" warranty period, there will be no charge for parts. You must carry-in or mail-in your product during the warranty period. If non-rechargeable batteries are included, they are not warranted. This warranty only applies to products purchased and serviced in the United States or Puerto Rico. This warranty is extended only to the original purchaser of a new product which was not sold "as is". A purchase receipt or other proof of the original purchase date is required for warranty service.

*Others*

**Carry-In or Mail-In Service**

For Carry-In or Mail-In Service in the United States call  
1-800-272-7033.

For assistance in Puerto Rico call Panasonic Puerto Rico, Inc.  
(787)-750-4300 or fax (787)-768-2910.

This warranty ONLY COVERS failures due to defects in materials or workmanship, and DOES NOT COVER normal wear and tear or cosmetic damage. The warranty ALSO DOES NOT COVER damages which occurred in shipment, or failures which are caused by products not supplied by the warrantor, or failures which result from accidents, misuse, abuse, neglect, mishandling, misapplication, alteration, faulty installation, set-up adjustments, misadjustment of consumer controls, improper maintenance, power line surge, lightning damage, modification, or commercial use (such as in a hotel, office, restaurant, or other business), rental use of the product, service by anyone other than a Factory Servicenter or other Authorized Servicer, or damage that is attributable to acts of God.

**THERE ARE NO EXPRESS WARRANTIES EXCEPT AS LISTED UNDER "LIMITED WARRANTY COVERAGE". THE WARRANTOR IS NOT LIABLE FOR INCIDENTAL OR CONSEQUENTIAL DAMAGES RESULTING FROM THE USE OF THIS PRODUCT, OR ARISING OUT OF ANY BREACH OF THIS WARRANTY.** (As examples, this excludes damages for lost time, travel to and from the servicer, loss of media or images, data or other memory content. The items listed are not exclusive, but are for illustration only.) **ALL EXPRESS AND IMPLIED WARRANTIES, INCLUDING THE WARRANTY OF MERCHANTABILITY, ARE LIMITED TO THE PERIOD OF THE LIMITED WARRANTY.**

Some states do not allow the exclusion or limitation of incidental or consequential damages, or limitations on how long an implied warranty lasts, so the exclusions may not apply to you.

This warranty gives you specific legal rights and you may also have other rights which vary from state to state. If a problem with this product develops during or after the warranty period, you may contact your dealer or Servicenter. If the problem is not handled to your satisfaction, then write to the warrantor's Consumer Affairs Department at the addresses listed for the warrantor.

**PARTS AND SERVICE WHICH ARE NOT COVERED BY THIS LIMITED WARRANTY ARE YOUR RESPONSIBILITY.**

Others

## Customer Services Directory (For USA Only)

---

**For Product Information, Operating Assistance, Literature Request, Dealer Locations, and all Customer Service inquiries please contact:**

**1-800-272-7033, Monday-Friday 8:30am-8pm EST.**

**Web Site: <http://www.panasonic.com/consumersupport>**

You can purchase parts, accessories or locate your nearest servicer by visiting our Web Site.

### Accessory Purchases:

Purchase Parts, Accessories and Instruction Books online for all Panasonic Products by visiting our Web Site at:

**<http://www.pasc.panasonic.com>**

or, send your request by E-mail to:

**[npcparts@us.panasonic.com](mailto:npcparts@us.panasonic.com)**

You may also contact us directly at:

**1-800-332-5368 (Customer Orders Only)**

**Panasonic Services Company 20421 84th Avenue South, Kent, WA 98032**

**(6 am to 5 pm Monday - Friday; 6 am to 10:30 am Saturday; PST)**

**(Visa, MasterCard, Discover Card, American Express, Check)**

### Product Repairs

#### Centralized Factory Servicer

MAIL TO :

Panasonic Services Company

1705 N. Randall Road,

Elgin, IL 60123-7847

Attention: Digital Camera Repair

Please carefully pack and ship, prepaid and insured, to the Elgin Centralized Factory Servicer.

Customer's in Puerto Rico, please ship or carry in to location below ("Service in Puerto Rico").

#### Service in Puerto Rico

Panasonic Puerto Rico, Inc.:

Ave. 65 de Infantería, Km. 9.5, San Gabriel Industrial Park, Carolina, Puerto Rico 00985

Phone (787) 750-4300 Fax (787) 768-2910

As of November 2004

## Index

<b>A</b>		<b>F</b>	
AC Adaptor .....	94, 96	File Number .....	23, 95, 102
AF Assist Lamp .....	74	Fine .....	72
AF Mode .....	73	Fireworks Mode .....	62
AF/AE Lock .....	30	Focus .....	31
Aspect Ratio .....	69	Folder Composition .....	95
Audio Dubbing .....	86	Folder Number .....	23, 95, 102
Audio Recording .....	54, 72	Food Mode .....	58
Auto Bracket .....	43	Formatting .....	91
Auto Review .....	22		
Auto White Balance .....	67	<b>H</b>	
		Histogram .....	27
<b>B</b>		<b>I</b>	
Baby Mode .....	60	ISO Sensitivity .....	69
Backlight Compensation .....	35		
Battery Carrying Case .....	104	<b>J</b>	
Brightness of the LCD Monitor .....	22	Jitter .....	31
Built-in Flash .....	38		
Burst Mode .....	45	<b>L</b>	
		Language Setting .....	24
<b>C</b>		Layout .....	98
Candle Light Mode .....	61	LCD Monitor .....	25, 100
Card Access Indication .....	17		
Charger .....	104	<b>M</b>	
Charging .....	14	Macro Mode .....	53
Clean-Up .....	90	MANUAL .....	79
Clock Set .....	20, 23	Mass Storage .....	93
Color Effect .....	76	Motion Picture Mode .....	53
Condensation .....	5	Multi Playback .....	48
<b>D</b>		<b>N</b>	
Date Printing .....	84, 99	Night Portrait Mode .....	59
Deleting Pictures .....	51	Night Scenery Mode .....	59
Demonstration		Normal Recording .....	29
of the Optical Image Stabilizer .....	44	NO.RESET .....	23
Digital Zoom .....	75	NTSC .....	24
DPOF Print Setting .....	83	Number of Prints .....	83, 97
		Number of Recordable Pictures .....	14, 18
<b>E</b>			
Economy Mode .....	23		
Exposure .....	32		
Exposure Compensation .....	42		
Extended Optical Zoom .....	71		
EZ .....	18, 37, 70, 71		

<b>O</b>		<b>S</b>	
Operation Tone .....	23	Scene Menu .....	24
Operation Tone Level .....	23	Scene Mode .....	56
Operational Sound .....	23	Scenery Mode .....	58
Optical Image Stabilizer .....	44	Self Portrait Mode .....	64
Optical Zoom .....	37	Self-timer .....	41
<b>P</b>		Setting Favorites .....	80
PAL .....	24	Setup Menu .....	21
Paper Size .....	97	Shutter Tone .....	23
Party Mode .....	62	Simple Mode .....	33
PC .....	93, 94	Slide Show .....	79
PictBridge .....	93, 96	Slow Shutter .....	75
Picture Adjustment .....	76	Snow Mode .....	63
Picture Quality Setting (Motion Picture Mode) .....	53	Soft Skin Mode .....	61
Picture Quality Setting (Simple Mode) .....	33	Sports Mode .....	57
Picture Size .....	18, 70	Spot-focusing .....	73
Pictures with Audio .....	77	Standard .....	72
Playback Pictures on TV .....	92	Starry Sky Mode .....	63
Playback Zoom .....	50	Status Indicator .....	14, 23
Playing Back Motion Pictures .....	77	<b>T</b>	
Portrait Mode .....	57	Trimming .....	88
Power LCD Function .....	26	<b>U</b>	
Power Save .....	22	USB Connection Cable .....	94, 96
Protect .....	85	USB Mode .....	24, 93, 94, 96
PTP .....	93	<b>V</b>	
<b>Q</b>		Video Output .....	24
Quality .....	72	Volume of Speakers .....	23
<b>R</b>		<b>W</b>	
Recording Guide Line .....	26	White Balance .....	67
Reset of Setting .....	24	White Balance Fine Adjustment .....	68
Resizing .....	87	White Set .....	68
Review .....	36	<b>Numerics</b>	
Rotate .....	82	1-area-focusing .....	73
Rotate Display .....	81	1-area-focusing (High speed) .....	73
		3-area-focusing (High speed) .....	73
		5-area-focusing .....	73

## Spanish Quick Use Guide/Guía rápida en español

Ésta es una visión de conjunto que trata del procedimiento para grabar y reproducir las imágenes con la cámara.

### 1 Cargue la batería.

- Cuando se envía la cámara, la batería está sin carga. Cárguela antes del uso.

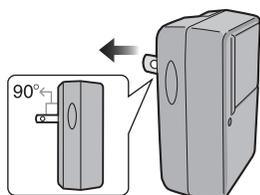

### 2 Inserte la batería y la tarjeta.

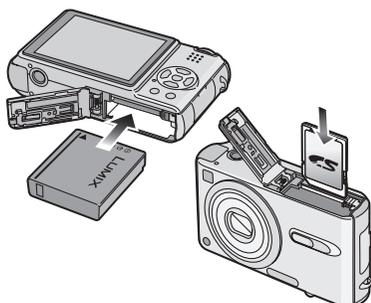

### 3 Encienda la cámara para tomar las imágenes.

- Ajuste el reloj.

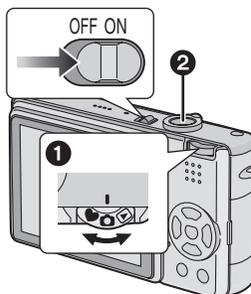

- 1 Ajuste el disco del modo a [📷].
- 2 Pulse el botón del obturador para tomar las imágenes.

### 4 Reproduzca las imágenes.

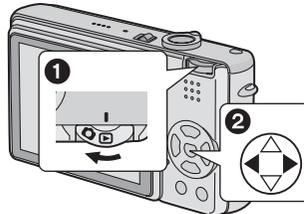

- 1 Ajuste el disco del modo a [▶].
- 2 Elija la imagen que quiere ver.

# *MEMO*

# *MEMO*



QuickTime and the QuickTime logo are trademarks or registered trademarks of Apple Computer, Inc., used under license.

**Panasonic Consumer Electronics Company,  
Division of Panasonic Corporation of North America**

One Panasonic Way, Secaucus, NJ 07094

**Panasonic Puerto Rico, Inc.**

Ave. 65 de Infantería, Km. 9.5, San Gabriel Industrial Park, Carolina, Puerto Rico 00985

**Panasonic Canada Inc.**

5770 Ambler Drive, Mississauga, Ontario, L4W 2T3

© 2005 Matsushita Electric Industrial Co., Ltd.



VQT0S57  
F0705Mn0 ( 2000 (A))  
©

