

# Samsung S7330

## Quick Start Guide



### Samsung S7330

- 3G
- User created theme
- MobileBlog
- RSS reader
- Camera and camcorder
- Synchronisation with Windows Media Player



# Contents

---

<b>Features</b>	<b>02</b>
<b>Precautions</b>	<b>02</b>
<b>Phone Layout</b>	<b>03</b>
<b>Set &amp; Link</b>	<b>04</b>
<b>Basic Use</b>	<b>04</b>
<b>Unpack</b>	<b>05</b>
<b>Solving Problem</b>	<b>06</b>

# Features

## **3G**

- Your phone is capable of operating in a 3G environment, allowing much greater data transfer speed, video streaming, and video conferencing.

## **USER CREATED THEME**

- Create your own theme using your favourite background images and colours.

## **MOBILEBLOG**

- Share your photos and videos on photo sharing websites and blogs.

## **RSS READER**

- Use RSS reader to get the latest news from your favourite websites.

## **CAMERA AND CAMCORDER**

- Use the camera module on your phone to take a photo or record a video.

## **SYNCHRONISATION WITH WINDOWS MEDIA PLAYER**

- Transfer music files to your phone directly from Windows Media Player.

## **MUSIC PLAYER**

- Play music files on your phone. You can use other phone functions while listening to music.

## **FM RADIO**

- Listen to your favourite radio stations anytime, anywhere.

## **DIGITAL DATA PRINTING**

- Print images, messages, and personal data directly from your phone.

## **BLUETOOTH**

- Transfer media files and personal data, and connect to other devices using wireless Bluetooth technology.

## **WEB BROWSER**

- Access the wireless web to get upto- the-minute information and a wide variety of media content.

# Precautions

**Failure to comply with the following precautions may be dangerous or illegal.**

## **DRIVE SAFELY AT ALL TIMES**

- Do not use a hand-held phone while driving. Park your vehicle first.

## **SWITCH OFF THE PHONE WHEN REFUELLING**

- Do not use the phone at a refuelling point (service station) or near fuels or chemicals.

## **SWITCH OFF IN AN AIRCRAFT**

- Wireless phones can cause interference. Using them in an aircraft is both illegal and dangerous.

## **INTERFERENCE**

- All wireless phones may be subject to interference, which could affect their performance.

# Precautions

## SWITCH OFF THE PHONE NEAR ALL MEDICAL EQUIPMENT

- Hospitals or health care facilities may be using equipment that could be sensitive to external radio frequency energy. Follow any regulations or rules in force.

## BE AWARE OF SPECIAL REGULATIONS

- Meet any special regulations in force in any area and always switch off your phone whenever it is forbidden to use it, or when it may cause interference or danger.

## WATER RESISTANCE

- Your phone is not water-resistant. Keep it dry.

## SENSIBLE USE

- Use only in the normal position (held to the ear). Avoid unnecessary contact with the antenna when the phone is switched on.

## EMERGENCY CALLS

- Key in the emergency number for your present location, then press .

## KEEP YOUR PHONE AWAY FROM SMALL CHILDREN

- Keep the phone and all its parts, including accessories, out of the reach of small children.

## ACCESSORIES AND BATTERIES

- Use only Samsung-approved accessories and batteries. Use of any unauthorised accessories could damage your phone and may be dangerous.

## QUALIFIED SERVICE

- Only qualified service personnel may repair your phone.

# Phone Layout

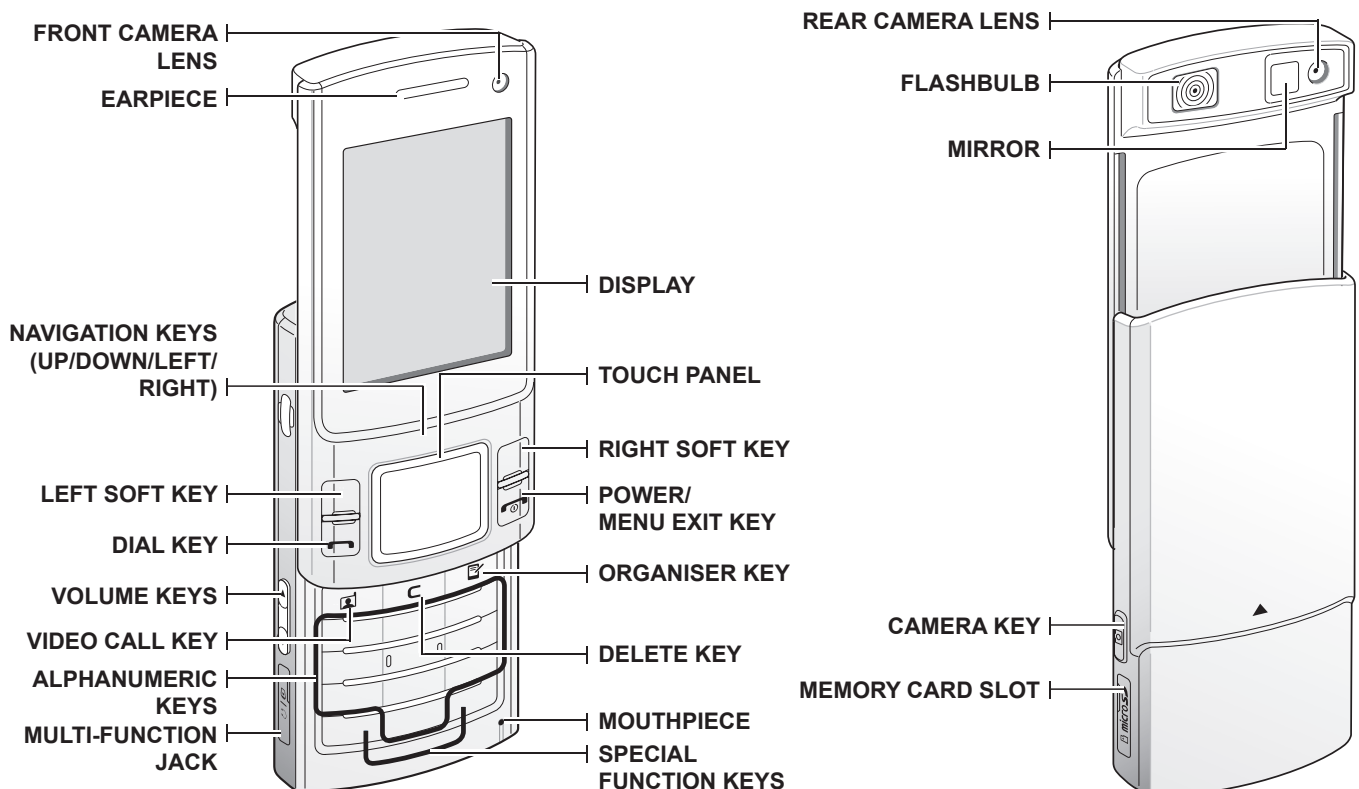

# Set & Link

First steps to operating your phone

## INSERT THE SIM CARD.

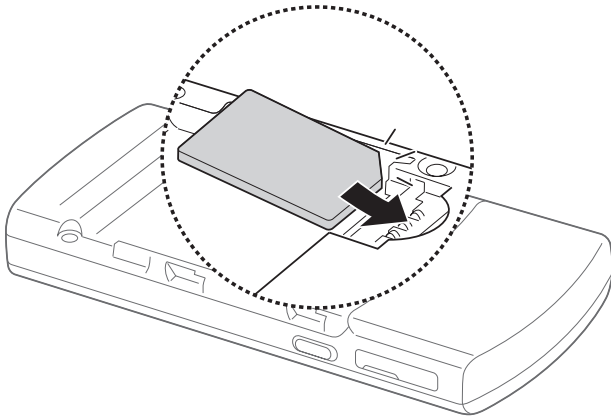

## INSERT THE BATTERY.

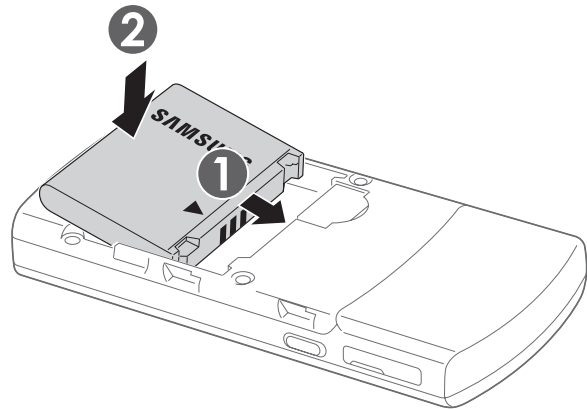

## REATTACH THE BATTERY COVER.

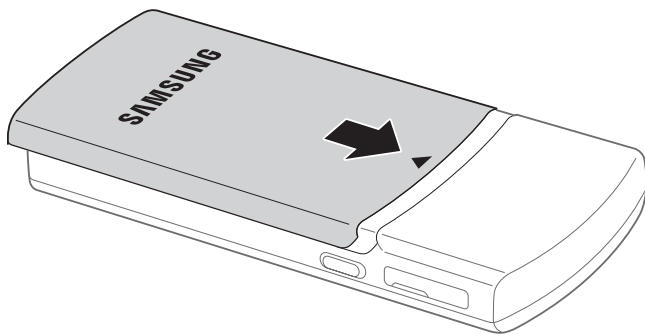

## PLUG THE TRAVEL ADAPTER INTO THE PHONE.

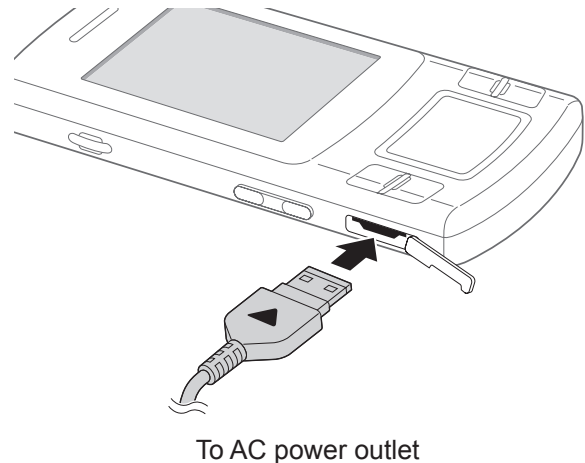

# Basic Use

## MAKE OR ANSWER CALLS

### Make a call

1. In Idle mode, enter an area code and phone number.
2. Press [📞]. Press [▲▼] to adjust the volume.
3. Press [📞] to end the call.

### Answer a call

1. When the phone rings, open the phone. If the phone is already open, press [📞].  
If it is a video call, press <Show me> to allow the caller to see you via the camera.
2. Press [📞] to end the call.

## ABC mode

### To enter a word:

Press the appropriate key until the character you want appears on the display.

## T9 mode

### To enter a word:

1. Press [2] to [9] to start entering a word.
2. Enter the whole word before editing or deleting characters.
3. When the word displays correctly, press [#] to insert a space.

# Unpack

Make sure you have each item

- Phone
- Travel adapter
- Battery
- User's Guide

You can obtain various accessories from your local Samsung dealer.

**Note:** The items supplied with your phone and the accessories available at your Samsung dealer may vary, depending on your country or service provider.

# Solving Problem

When you switch your phone on, the following messages may appear

## **“INSERT SIM”**

- Make sure that the SIM card is correctly installed

## **“PHONE LOCK”**

- The automatic locking function has been enabled.  
You must enter the phone's password before you can use the phone.

## **ENTER PUK**

- The PIN code was entered incorrectly three times in succession and the phone is now blocked.  
Enter the PUK supplied by your service provider.

## **ENTER PIN**

- You are using your phone for the first time.  
You must enter the Personal Identification Number (PIN) supplied with the SIM card.
- The PIN Check feature is enabled. Every time the phone is switched on, the PIN has to be entered. To disable this feature, use the PIN check menu.

## **“NO SERVICE,” “NETWORK FAILURE,” OR “NOT DONE” DISPLAYS**

- The network connection has been lost. You may be in a weak signal area. Move and try again.
- You are trying to access an option for which you have not taken out a subscription with your service provider. Contact the service provider for further details.

## **YOU HAVE ENTERED A NUMBER BUT IT WAS NOT DIALLED**

- Make sure that you have pressed SEND
- Make sure that you have accessed the right cellular network.
- Make sure that you have not set an outgoing call barring option.

## **A CALLER CANNOT REACH YOU**

- Make sure that your phone is switched on. (Press END for more than one second.)
- Make sure that you are accessing the correct cellular network.
- Make sure that you have not set an incoming call barring option.

# Solving Problem



## **YOUR VOICE IS NOT HEARD AT THE OTHER END**

- Make sure that you have switched on the microphone.
- Make sure that you are holding the phone close enough to your mouth.  
The microphone is located at the bottom of the phone.

## **THE PHONE STARTS BEEPING AND “BATTERY LOW” FLASHES ON THE DISPLAY**

- Your battery is insufficiently charged. Recharge the battery.

## **THE AUDIO QUALITY OF THE CALL IS POOR”**

- Check the signal strength indicator on the display (  ).  
The number of bars indicates the signal strength from strong (  ) to weak (  ).
- Try moving the phone slightly or moving closer to a window if you are in a building.

## **NO NUMBER IS DIALLED WHEN YOU RE-CALL A ADDRESS ENTRY**

- Use the Phonebook feature to ensure the number has been stored correctly.
- Store the number again, if necessary.

## **THE BATTERY DOESN'T CHARGE PROPERLY OR THE PHONE SOMETIMES TURNS ITSELF OFF**

- Wipe the charging contacts both on the phone and on the battery with a clean soft cloth.

## **IF THE ABOVE GUIDELINES DO NOT HELP YOU TO SOLVE THE PROBLEM, TAKE NOTE OF**

- The model and serial numbers of your phone
- Your warranty details
- A clear description of the problem